

Sudden Unintended Acceleration in an All-Electric Vehicle

by

Ronald A. Belt
Plymouth, MN 55447
27 February 2015

Abstract: Six sudden unintended acceleration incidents have been reported with Tesla's Model S all-electric vehicle following its introduction in 2012. The cause of these incidents is explained by a runaway condition in the traction motor controller that is precipitated by a negative voltage spike on the battery supply line. This explanation is very similar to the author's explanation for a runaway condition in the electronic throttle controller of gasoline engines, which explains the cause of sudden unintended acceleration in vehicles having electronic throttles. The root cause of the problem is explained, and potential solutions are discussed.

I. Introduction

Sudden acceleration has been observed in all makes and models of automobiles having electronic throttles. This includes hybrid electric vehicles, which have an internal combustion engine (ICE) that uses an electronic throttle. The author has developed an electronic theory of sudden acceleration which explains the cause of sudden acceleration in all vehicles having electronic throttles¹. The cause is attributed to a negative voltage spike which upsets the control system for the electronic throttle, resulting in a wide open throttle. Soon after developing this theory, the author found what appeared to be a new sudden acceleration incident involving an all-electric vehicle having no electronic throttle². Did this mean that his theory was wrong, or was there was a second cause of sudden acceleration besides the one he identified? This led the author to probe deeper into the cause of sudden acceleration in the vehicle involved in the latest incident; namely the Tesla Model S all-electric vehicle. The following sections describe what he found.

II. Sudden Acceleration Incidents in the Tesla Model S Vehicle

Six sudden unintended acceleration incidents have occurred with the Tesla Model S vehicle since its introduction in 2012. The following are brief descriptions of these incidents:

1. Incident #1. February 15, 2015. Crash into an Issaquah, Washington, bank building. The crash occurred at 9:00 a.m. while the driver was parking his car in front of the bank so he could use an ATM machine. The car jumped the curb and crashed through the brick wall of the bank building. No injuries were reported. The following photos show the damage done.³



2. Incident #2. August 2014. Crash into a Bakersfield, California, sushi restaurant. The crash occurred at 9:30 p.m. on a Saturday evening, when there were about thirty customers in the restaurant. Two injuries were reported requiring hospital care, but no deaths occurred. The driver was not arrested or charged with a driving offense because police found that neither drugs nor alcohol were involved. Police speculated that the driver mistakenly hit the accelerator while trying to apply the brakes. The following photos show the restaurant and the vehicle in the restaurant.⁴



3. Incident #3. August 2013. Crash into a Camarillo (Ventura county), California, fish restaurant. The crash occurred at 11:11 a.m. when the vehicle jumped the curb and crashed into the restaurant. The driver, a 71-year old woman, claimed to have applied the brake, but the car lurched forward despite her efforts. There were four passengers in the car with the driver. The restaurant area involved was unoccupied at the time, so no injuries were reported. The following photo shows the vehicle in the restaurant.⁵



4. Incident #4. July 14, 2014. Crash into a Tesla sign in Fremont, California. The crash occurred at Tesla's supercharger battery charging station in Fremont, California. The vehicle first hit the Tesla store building, and then the Tesla sign. The following photo shows the vehicle after the crash. No injuries were reported.⁶



5. Incident #5. September 21, 2013. San Diego, California. A driver was pulling down a driveway with the brake “constantly applied” when the car suddenly accelerated, hit a curb, and the middle portion of the car landed on a 4.5-ft. high vertical retaining wall. The front portion of the car was hanging up in the air. The owner contacted Tesla about the malfunction. A Tesla engineer stated that the “accelerating pedal was stepped on and it accelerated from 18 percent to 100 percent in a split second.” The same engineer also claimed that the car has a built-in safeguard that prevents the acceleration from going beyond 92 percent. The driver noted that these two statements are contradictory. The following complaint⁷ was filed with NHTSA:

NHTSA ID Number: 10545230, Filed: 09/24/2013, Date of incident: 09/21/2013:

“The car was going at about 5 mph going down a short residential driveway. Brake was constantly applied. The car suddenly accelerated. It hit a curb and the middle portion of the car landed on a 4.5 ft high vertical retaining wall. The wall is one foot away from the curb. The front portion of the car was hanging up in the air. The car was at about 45 degree up and about 20 degree tilted toward the right side. An engineer from Tesla said the record showed the accelerating pedal was stepped on and it accelerated from 18% to 100% in split second. He blamed my wife stepping on the accelerating pedal. But he also said there was a built-in safe-guard that the accelerator could not go beyond 92%. The statements are contradictory. If there is a safeguard that the accelerator cannot go beyond 92%, there would be no way that my wife could step on it 100%. There was some mechanical problem that caused the accelerator to accelerate on its own from 18% to 100% in split second.”

6. Incident #6. September 26, 2013. Laguna Hills, California. The following complaint⁸ was filed with NHTSA:

NHTSA ID Number: 10545488, Filed: 09/26/2013, Date of incident: 09/29/2013:

“I was at a full stop waiting to turn left into the parking garage. When it was clear of oncoming traffic for me to make the left turn, I released my foot off the brake pedal and the car instantly surged forward very fast and hit another vehicle parked in the front of the garage. This all happened so quickly that I did not have time to avoid the impact. The time of occurrence was in broad daylight at about 6:00 p.m. PST. I have driven this car for almost 10000 miles prior to the accident and know how to handle the car and understand the torque this car has. I have made thousands upon thousands of stops and starts with this vehicle and this is the first time this has ever happened. There is no other term to describe this other than sudden acceleration. The local police department dispatched an officer and no drugs or alcohol was involved. Tesla instructed their staff to not communicate with me about this accident.”

The only feature common among these six incidents is that the vehicle was out of control, crashing after accelerating from an idle state. Only in incidents 3, 5, and 6 do we even have a statement from the driver that the acceleration was unintended, and that it occurred while the driver was applying the brakes. Therefore, it is difficult to claim from the incident reports alone that all six incidents have a common cause, let alone that the cause is sudden unintended acceleration. Yet, the inference is often made by police investigators, the press, and many in the general public, that all of these incidents have a common cause in the driver mistaking the accelerator pedal for the brake pedal. And if it is clear that the driver’s ability to control the vehicle was not impaired by drugs or alcohol or a medical condition, then it is often claimed that the driver was impaired by old age. This generally accepted common cause should be recognized as a prejudiced assumption unsupported by any real evidence. To show that it is a prejudiced assumption, we now present an alternative explanation for all these incidents which lies in the vehicle’s control system, and not in the driver’s impaired behavior.

III. The Cause of Sudden Acceleration in the Tesla Model S Vehicle

In a previous paper⁹, the author provided an explanation for sudden acceleration in all vehicles having electronic throttles whereby a wide open throttle condition in the electronic throttle controller is

precipitated by a negative voltage spike on the battery supply line. If a negative voltage spike occurs while the battery voltage is being read by an A/D converter, then the compensation coefficient used to correct the PWM duty cycle of the electric throttle motor for low battery voltage causes the throttle motor to open slightly more than intended. If this electric throttle motor is part of a control loop regulating the engine speed, as it is in all vehicles having electronic throttles, then each time the control loop is traversed, the throttle motor opens the throttle valve a little bit more than intended. Since the loop is traversed every 10 milliseconds or so, the throttle opening is incremented at a rate of nearly 100 times a second, which causes the throttle valve to go to a wide open state in less than one second. This all happens while the driver's foot is off the accelerator pedal. The driver's only possible response is to control the vehicle while it is suddenly raging at full throttle, either by applying the brakes, or by quickly turning off the ignition or by putting the transmission into neutral. The brakes are less effective in this situation because the transmission remains in low gear, which multiplies the engine's torque to the wheels by a factor of four to five instead of by a factor of two to three as it does in a higher gear. Also, pumping the brakes more than two or three times causes the pressure in the power brake accumulator to dissipate, which causes the power brakes to lose their effectiveness. And turning off the ignition or putting the transmission into neutral is frequently complicated by a start/stop pushbutton which must be held down for five seconds to turn off the ignition, or by an electronic transmission controller which must process the driver's request to shift while the transmission controller is engaged in operating the engine at its maximum RPM. Therefore, the vehicle frequently crashes into a stationary object in the less than one to five seconds it takes to bring the vehicle back under control.

There is only one problem with applying the author's theory of sudden acceleration to the sudden acceleration incidents discussed in Section I. The Tesla model S vehicle does not have an electronic throttle. This is only an apparent difficulty, however. Further reflection on the problem reveals that the traction motor on an electric vehicle is similar from a control standpoint to the electronic throttle motor on a gasoline engine. However, it draws an electric current of over 1000 amps instead of only 10 amps or less, making it more much more powerful. This is because the traction motor on the Model S is a three-phase induction motor instead of a permanent magnet DC motor for the electronic throttle. But if one knows how sudden acceleration in a vehicle with an electronic throttle originates in the way the electronic throttle motor is controlled, then one can see the parallels between the two types of motors in the two types of vehicles.

Specifically, sudden acceleration in a vehicle with an electronic throttle has been shown to be the result of two necessary conditions:

- 1) A control loop controlling the electric throttle motor, which contains a look-up table or map with the engine speed as one input variable, and with the engine speed being proportional to the torque generated by the electric throttle motor,
- 2) A voltage compensation operation which is meant to stabilize the supply voltage to the electric throttle motor, but which becomes defective when the supply voltage is sampled during a negative voltage spike, which causes an incorrect voltage compensation coefficient that increments the throttle motor torque each time the loop is traversed, causing the throttle to open further each time until the throttle valve reaches a wide open position.

With this understanding of the problem, a study of the Tesla Model S control system was undertaken to determine whether these two conditions were present. The following sub-sections describe what was found.

Control Loop with a Map Having Speed as One Input Variable. The Tesla Model S vehicle comes in four variations, as shown in Table 1. Two of the variations have one traction motor in the rear only, while the other two variations have two traction motors, one in the front and one in the rear, as shown in Figure 1.

	Model S 60	Model S 85	Model S 85D	Model S P85D
Battery Capacity	60 kWh	85 kWh	85 kWh	85 kWh
Primary Motor (rear)	380 hp	380 hp	188 hp	470 hp
Assist Motor (front)	---	---	188 hp	221 hp

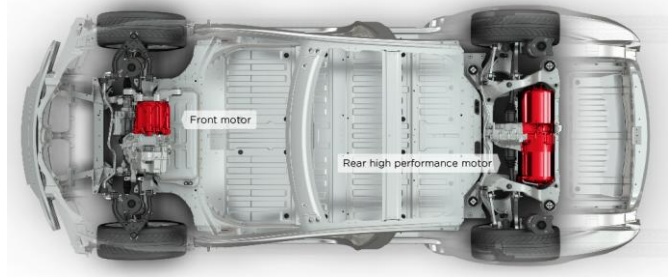

Table 1. Tesla Model S variations¹⁰

Figure 1. Traction motor locations¹⁰

All four variations of the Tesla S vehicle use the same motor controller. A block diagram of this motor controller is shown in Figure 2. One can see that there is a control loop through the controller which uses both engine speed and wheel speed as feedback terms from the traction motors to the controller inputs, and that the loop contains a look-up table or map which has the vehicle speed as one of its inputs. The table contains torque and flux commands for both motors if two traction motors are used, but torque and flux commands for one only motor if just one traction motor is used. Since the Tesla vehicles have no torque converter, the vehicle speed is always proportional to the traction motor speed.

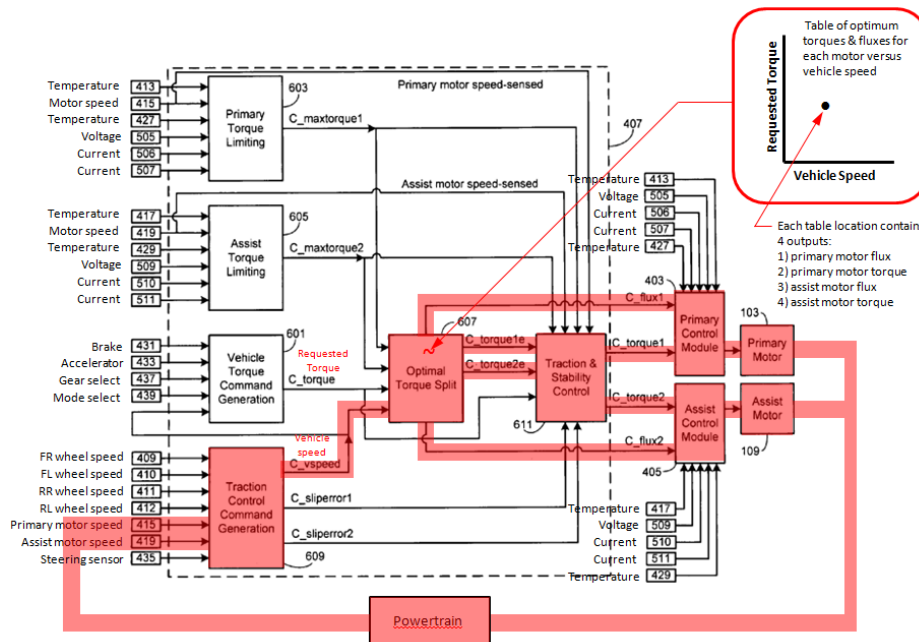

Figure 2. The Tesla Model S torque and traction controller from Tesla patent No. 7747363¹¹.

The controller contains a loop with a map that has vehicle speed as an input variable.

Voltage Compensation Operation. Tesla Motors advertises that their Model S traction motors are three-phase induction motors¹² powered by bipolar inverters¹³. We know that the inverter transistors are switched by flux vector control units because Figure 2 from Tesla's patent shows torque and flux inputs to the motor control modules¹⁴. A typical motor control module is shown in Figure 3. It contains two PID control loops, one for the torque and one for the flux. Since the motor's rotation causes the torque and flux vectors within the motor to change with time, making the vectors dependent on the angle of rotation, a rotating Park transformation is used to de-rotate the torque and flux vectors within the motor, making them time independent. They can then be subtracted from the incoming torque and flux commands, which are independent of one another. An inverse Park transformation is then used to transform the combined PID controller values back into the rotating motor frame. Forward and inverse Clark

transformations are used to transform coordinates between two-space and three-space. All of the flux vector control operations are carried out by a single programmable DSP chip as shown by the shaded box of Figure 3. The PWM outputs of the DSP chip are then used to switch the bipolar inverter transistors. It is assumed in Figure 3 that a rotation sensor is used to determine the motor's angle of rotation. This provides finer control at low motor speeds and at motor start-up than sensorless flux vector control units, which determine the motor's rotation angle by estimating the flux vector angle from the measured inverter currents.

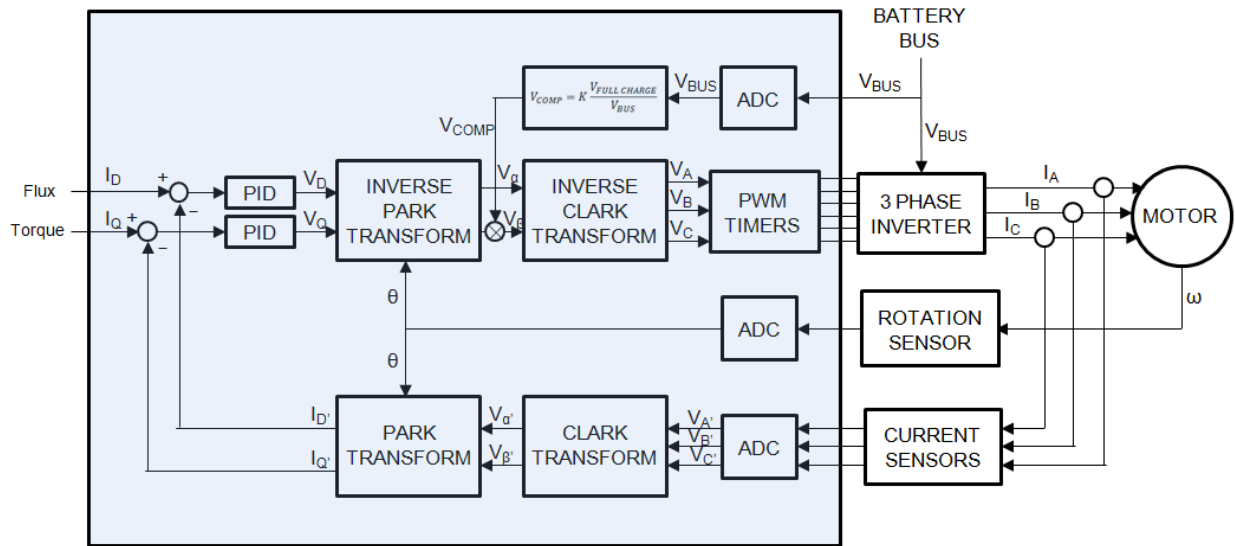

Figure 3. The Tesla S primary and assist control modules use a flux vector control algorithm to switch the three-phase inverter transistors.

The flux vector control scheme makes three-phase motor operation behave like that of a simpler DC permanent magnet motor in which the input torque command is independent of the motor flux. In both cases, the motor current is proportional to the DC battery supply voltage, making the output motor torque rise or fall with the DC battery supply voltage. In order to keep the motor torque constant while the battery supply voltage changes as the battery discharges with use, the DC supply voltage is sampled periodically and used to create a compensation coefficient that is inversely proportional to the supply voltage. This inverse compensation term is then used to multiply the input torque command on the DSP controller chip, which stabilizes the output motor torque with respect to supply voltage changes^{15,16}.

This all works correctly as long as the sampled battery bus voltage corresponds to the DC value of the supply voltage powering the inverter. But if a negative voltage spike occurs while the DC voltage is being sampled, then the sampled voltage no longer corresponds to the DC supply voltage. Instead, an incorrect voltage compensation coefficient is created which gets applied to the input torque command, causing the output motor torque to increase above the value associated with the normal supply voltage. This leads to the output motor torque being greater than the value specified by input torque command. This incrementing of the input torque command occurs each time the outer control loop in the torque and traction controller is being traversed. If the output motor torque causes the map in the control loop to issue a new torque command that is larger than the previous one because the vehicle speed is higher, then this new motor torque command will also be incremented to give an even larger output motor torque. The result will be a runaway of the motor torque to the highest possible torque value achievable by the traction motor. This can be substantial from a stopped position because the maximum torque of an electric traction motor is constant with speed down to a stopped position.

So we see that there is a common explanation for the existence of sudden acceleration in Tesla Model S vehicles and in vehicles with electronic throttles. Both types of vehicles have a control loop which contains a look-up table or map with one input variable being proportional to the engine speed or vehicle speed. And both types of vehicles have a voltage compensation operation meant to stabilize the voltage to the electric throttle motor or traction motor, but which becomes defective when the supply voltage is sampled during a negative voltage spike. The resulting incorrect voltage compensation coefficient increments the throttle motor torque each time the control loop is traversed, with the map in the loop causing each new motor command to be related to the previous motor output. This causes the electric motor or traction motor to go to its maximum torque position, which causes sudden unintended acceleration. The only differences between the two cases are: 1) the type of electric motor, being a permanent magnet DC motor for the electronic throttle versus a three-phase induction motor for the traction motor, 2) the motor current, being less than 10 amps for the electronic throttle motor versus over 1000 amps for the traction motor, and 3) the DC battery voltage, being 12.6 volts for the electronic throttle motor versus around 400 volts for the traction motor. These differences are unimportant from a motor control standpoint.

IV. Potential Solutions for Sudden Acceleration in the Tesla Model S Vehicle

Sudden acceleration can be prevented in the Tesla Model S vehicle either by preventing negative voltage spikes from occurring during the sampling of the battery bus voltage, or by rejecting the sampled bus voltage if it has been corrupted by a negative voltage spike, and then re-sampling the battery bus voltage to get the true DC voltage value. The use of a capacitor to stabilize the bus voltage during a negative voltage spike is ineffective because the required current is too large for most capacitors of practical size. Also, the use of a separate battery bus for powering the electric traction motor is not possible as it might be with an electronic throttle motor because it requires a second battery. Therefore, rejecting corrupted samples is probably the most attractive solution. This can be done by taking multiple voltage samples at times far enough apart so that the negative voltage spikes will affect at most one sample. Then the multiple samples can be compared by various means, and the corrupted sample rejected. The remaining samples can then be used to create the DC voltage value required. There may be other techniques to determine the battery bus voltage based on monitoring the state of charge of the traction battery. These techniques could be used if they are not susceptible to corruption by negative voltage spikes.

Another solution for preventing sudden acceleration in the Tesla Model S vehicle is to detect sudden acceleration after it starts by using a vehicle acceleration sensor. If vehicle acceleration is detected even while the accelerator pedal is released, then a signal could be generated which interrupts the drive signals to the traction motor inverter. The interruption can be done by switching relays in the path of the inverter drive signals, changing the relays from a normally closed state to an open state. This would immediately stop the traction motors, causing sudden acceleration to cease. This technique can also be used to stop sudden acceleration in vehicles having an electronic throttle motor, where it has been made into a commercially available product called the Decelerator^{17,18}.

V. Conclusion

An alternative theory to driver pedal confusion has been presented for explaining sudden acceleration in the Tesla model S vehicle. Although this alternative theory has not yet been tested, it does have one advantage over the rival pedal confusion theory; namely, it is supported by additional evidence. The additional evidence is the testimony of many drivers who have maintained that their foot was not on the accelerator pedal during the sudden acceleration incident. The pedal confusion theory is inconsistent with the testimony of these drivers and requires dismissing their testimony by making a second assumption that their testimony is flawed or even criminally deceptive in order to obtain money from the auto

manufacturers. The new theory does not require dismissing the testimony of these drivers. Therefore, the new theory should be preferred on the basis of Occam's razor, which states that the explanation having the fewest assumptions is more likely to be the true explanation.

In summary, six sudden unintended acceleration incidents involving Tesla's Model S all-electric vehicle have been discussed. The cause of these incidents has been explained by a runaway condition in the traction motor controller that is precipitated by a negative voltage spike on the battery supply line. This explanation is very similar to the author's explanation for a runaway condition in the electronic throttle controller of gasoline engines, which explains the cause of sudden unintended acceleration in vehicles having electronic throttles. The root cause of the problem has been explained, and potential solutions have been discussed.

VI. References

-
- ¹ R. Belt, "Simulation of Sudden Acceleration in a Torque-Based Electronic Throttle Controller", <http://www.autosafety.org/dr-ronald-belt%E2%80%99s-sudden-acceleration-papers>.
- ² <http://www.komonews.com/news/local/No-injuries-when-Tesla-crashes-into-Issaquah-bank-292013251.html>
- ³ <http://www.komonews.com/news/local/No-injuries-when-Tesla-crashes-into-Issaquah-bank-292013251.html>
- ⁴ <http://insideevs.com/tesla-model-s-ends-inside-sushi-restaurant/>
- ⁵ <http://insideevs.com/tesla-model-s-crashes-through-restaurant-driver-blames-it-on-unintended-acceleration/>
- ⁶ <http://www.streetinsider.com/Insiders+Blog/Tesla+%28TSLA%29+Model+S+Crashes+into+Tesla+Store+Sign/9657850.html>
- ⁷ <http://www.aboutautomobile.com/Complaint/2013/Tesla/Model+S/10545230>
- ⁸ <http://www.aboutautomobile.com/Complaint/2013/Tesla/Model+S/10545488>
- ⁹ R. Belt, "Simulation of Sudden Acceleration in a Torque-Based Electronic Throttle Controller", <http://www.autosafety.org/dr-ronald-belt%E2%80%99s-sudden-acceleration-papers>.
- ¹⁰ <http://www.teslamotors.com/models>
- ¹¹ Y. Tang, "Traction Control System for an Electric Vehicle", U.S. patent no. 7747363, issued June 29, 2010, assigned to Tesla Motors. See also Tesla patents 7739005, 7742852, and 8453770 having the same title, but different claims.
- ¹² <http://www.teslamotors.com/blog/induction-versus-dc-brushless-motors>, http://my.teslamotors.com/fr_CA/node/3856
- ¹³ <http://www.teslamotors.com/blog/engineering-update-powertrain-15>
- ¹⁴ Flux vector control is also mentioned in an article by *Engineering and Technology* magazine at <http://eandt.theiet.org/magazine-/2012/07/more-motor-less-power.cfm>.
- ¹⁵ The author has explained in reference 1 how a lower DC bus voltage powering the electronic throttle motor causes the throttle motor to have a lower torque, leading to a smaller throttle opening and a lower engine RPM. When this smaller throttle opening is applied each time the control loop is traversed through the map, then the throttle opening is made even smaller, causing the throttle opening to go to zero, and the engine to stall. The same behavior applies to the Tesla electric vehicle's traction motor. Therefore, it is essential to compensate for this effect of a lower bus voltage on the traction motor by increasing the torque command to the traction motor by an amount equal to the inverse of the battery voltage.
- ¹⁶ Zilog Application Note AN-024703-1111, "Vector Control of a 3-Phase AC Induction Motor using the Z8FMC16100 MCU", available at: http://www.zilog.com/appnotes_download.php?FromPage=DirectLink&dn=AN0247&ft=Application%20Note&f=YUhSMGNEb3ZMM2QzZHk1NmFXeHZaeTVqYjIwdlpHOWpjeTk2T0dWdVkyOXlaVzFqTDJGd2NHXZkRlZ6TDJGdU1ESTBOeTV3WkdZPQ shows the following functional block diagram of their Z8FMC16100 MCU chip, which contains a bus voltage sampling operation providing an input to a bus ripple compensation operation. The ripple compensation turns out to be the inverse of the inverter power bus voltage.

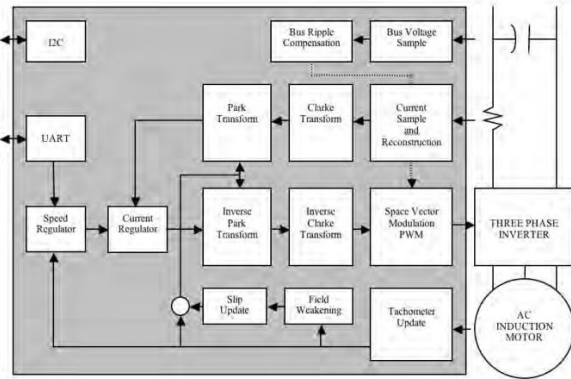

Figure 8. Functional Block Diagram

Read Bus Voltage

The bus voltage is sampled through the microcontroller's ADC. Currently it is used for ripple compensation; however, it could also be included in field-weakening calculations or used for over-voltage shutdown protection.

Bus Ripple Compensation

This routine tracks changes in the bus voltage and looks up a precalculated ripple compensation factor which is inversely proportional to the ADC sample of the bus voltage. The PWM duty cycle is scaled by this factor to compensate for variations in the DC bus voltage so that a smaller factor value corresponds to a reduced PWM duty cycle which clamps the output waveform to a nominal voltage.

This application uses a nominal bus voltage of 225VDC. At this voltage, the output factor is 255 (full scale, no compensation). The factor scales down to 0 at 375VDC or higher, providing an overvoltage shutdown. Between 225VDC and 375VDC, the look-up table values are calculated using the following equation:

$$pwm_correction = \frac{ADC_ybus_nom}{ADC_ybus} \times 255$$

¹⁷ D. Cook, "System for Disabling Engine Throttle Response", US Patent Application 2011/0196595 A1, August 11, 2011.

¹⁸ <http://www.marketwired.com/press-release/solutions-group-accelerates-awareness-decelerator-with-twitter-facebook-internet-search-1160940.htm>