

Simulation of Sudden Acceleration in a Torque-Based Electronic Throttle Controller

by

Ronald A. Belt
Plymouth, MN 55447
30 January 2015

Abstract: The Bosch torque-based engine controller is used by auto manufacturers world-wide for the electronic throttle control systems of their cars, trucks, buses, motorcycles, and boats. Simulation of the Bosch engine controller shows that it can experience a runaway open-throttle condition when operating with a slightly higher throttle gain associated with an incorrect battery voltage compensation caused by sensing the battery voltage during a negative-going voltage spike on the battery supply line produced by one of the vehicle's accessory electric motors turning on. This runaway open-throttle condition has all the characteristics of sudden acceleration in automobiles, and can explain the sudden acceleration of all vehicles with electronic throttles worldwide. This paper describes the Bosch torque-based engine controller, its simulation, and approaches for testing for the runaway condition in actual vehicles. Implications of the paper's results are described.

I. Introduction

Sudden acceleration has been observed in all makes and models of automobiles worldwide from all manufacturers, including Hyundais and Kias in Korea, Mitsubishi Monteros in the Philippines, and Toyotas, Fords, Jeeps, and nearly every other make of vehicle in the United States and Europe. In 2015 this phenomenon continues to cause storefront crashes, garage door crashes, parking lot crashes, and even falls of cars from elevated parking lots, many of which have resulted in death. Incidents can happen while the transmission is in either drive or reverse, or even in both successively. Brake-throttle override has been unsuccessful in eliminating such incidents, all of which are blamed on the driver mistaking the accelerator pedal for the brake. The author has developed an electronic theory of sudden acceleration which explains this phenomenon in several papers which are available on the Internet.¹ This paper continues where his latest paper left off², by explaining the engine controller in greater detail and by giving a simulation of its operation showing how an incorrect battery voltage compensation can cause a runaway open throttle condition. The implications of this finding are discussed.

II. Electronic Throttle System with Engine Controller

Figure 1 shows a block diagram of an electronic throttle system without the engine controller. It consists of a throttle valve actuator with its PID controller, a dual-redundant throttle position sensor, a MAF sensor to measure air flow, and the engine itself with a crankshaft position sensor to measure the engine RPM. The PID controller is a feedback-type controller that computes a new throttle opening command every 2 milliseconds. The PID coefficients are changed, or scheduled, with engine operating condition, with lower gains making the throttle operation less sensitive in the vehicle's PARK and NEUTRAL modes and higher gains making it more sensitive in the vehicle's DRIVE and REVERSE modes. The PID controller controls a PWM controller that produces a pulse width modulated waveform that operates an H-bridge which turns on and off the electric throttle motor, making its torque proportional to the duty cycle of the PWM waveform. This torque, acting against a spring which brings the throttle valve back to its semi-closed idle position, determines the throttle opening in response to the driver's accelerator inputs.

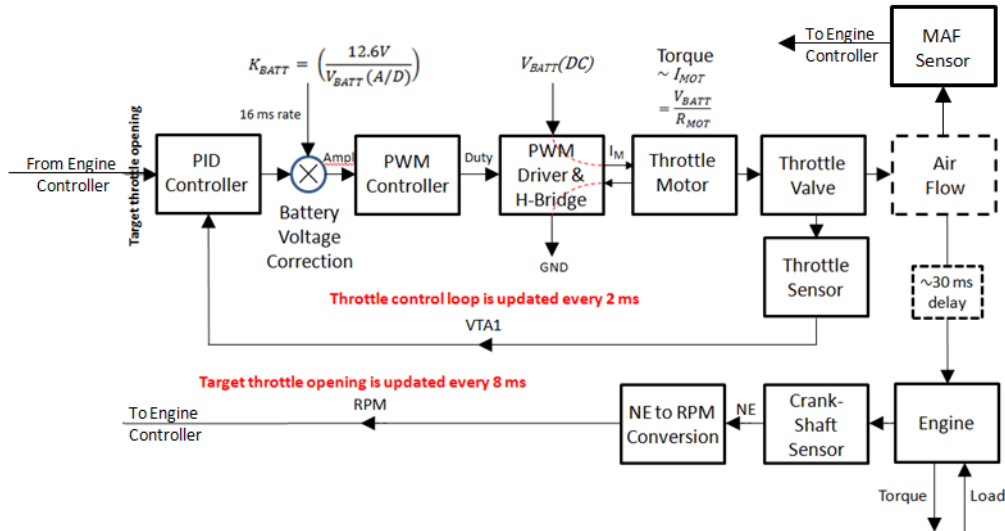

Figure 1. Engine with electronic throttle actuator (plant being controlled)

For a constant PWM duty cycle, the throttle motor torque is proportional to the battery voltage, which means the throttle opening changes with the battery voltage. This can cause the engine torque to decrease as the battery voltage decreases. This will be unnoticeable to a driver, who needs only to press on the accelerator a little more as the battery voltage decreases. But engine idle-ups and other engine functions require a precise amount of engine torque to function properly, and will not operate properly if the engine torque decreases due to a decrease in battery voltage.^{Footnote 1} To prevent this from happening, the PWM duty cycle is multiplied by a compensation term which depends on the inverse of the battery voltage in order to make the throttle opening independent of the battery voltage. Unfortunately, if the battery voltage is sensed while a negative-going voltage spike is present, then the compensation term increases the throttle opening when there may be no need to increase the throttle opening because the DC value of the battery voltage may not have changed. This is the root cause of the sudden acceleration phenomenon. The probability of this happening is what controls the probability that a vehicle will have sudden acceleration. This theory does not require the failure of any hardware or software, or any parasitic connections that may be produced by tin whiskers.

Figure 1 constitutes what is known in control theory as the plant, or what is being controlled. The controller for this plant is shown in Figure 2. This controller is a torque-based engine controller developed by Bosch in 1997. It is used in some form by all auto manufacturers for their electronic throttle controlled engine systems. Its widespread usage is the result of its ability to conveniently control not only the driver's demand for engine torque via the accelerator pedal, but also all the other demands for engine torque created by the vehicle internal and external to the ECU as shown on the left in Figure 2. It also allows the easy incorporation of cruise control and other torque-based vehicle functions such as electronic stability control.

Figure 1 was created by the author using information found in Bosch educational publications³, Bosch patents⁴, and other references available in the engine tuning community⁵. Before discussing its simulation, the following comments are in order:

^{Footnote 1} It will be shown later that a decrease in engine torque with decreasing battery voltage results in an engine stall because the additional torque generated is insufficient to counteract the load produced by the accessory, such as a belt-powered air conditioning pump.

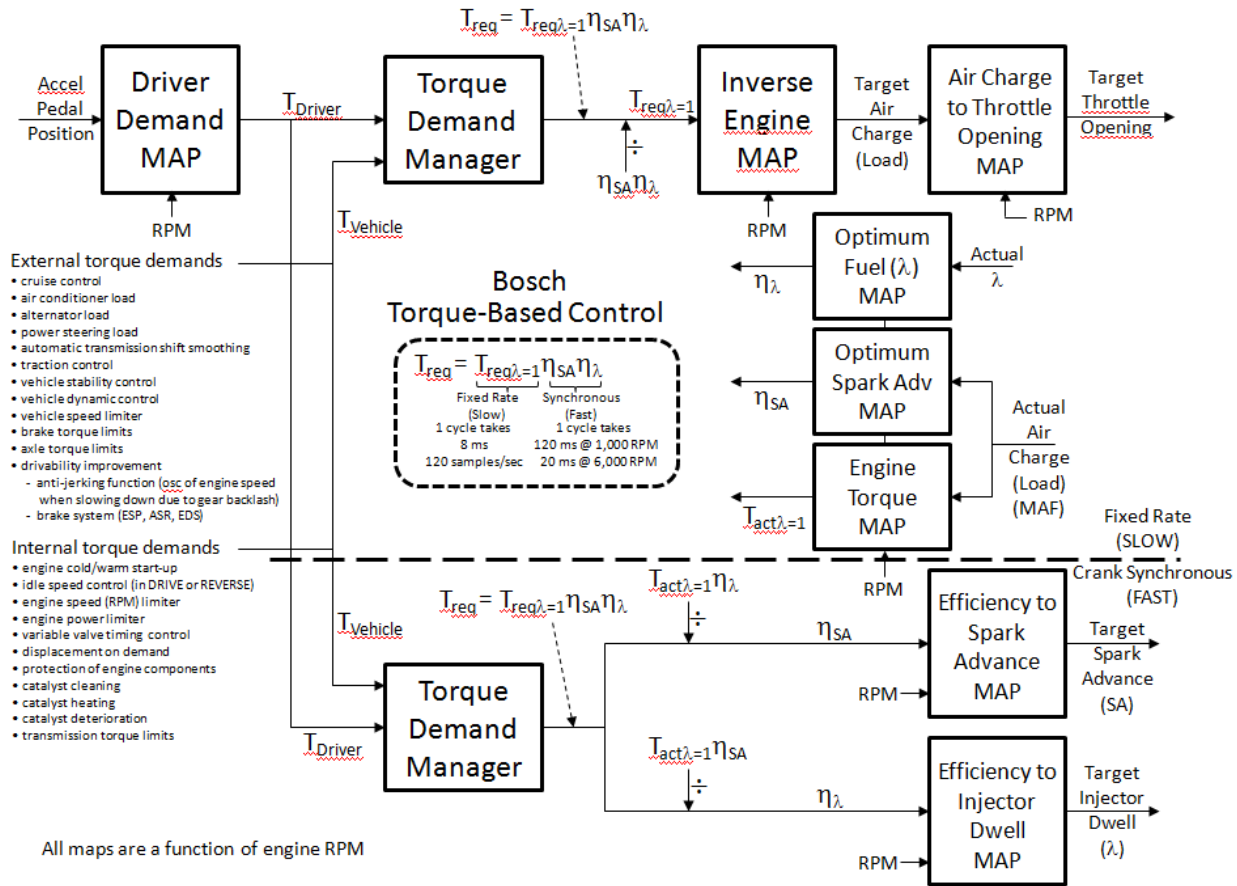

Figure 2. Torque-based controller for engine with electronic throttle system

Comments on Figure 2:

- As shown in the inset to Figure 2, the Bosch torque-based engine controller assumes that the engine torque can be represented as a product of a fixed rate torque component, $T_{req\lambda=1}$, and two synchronous components, η_{SA} and η_{λ} , known as efficiencies. The fixed rate torque component $T_{req\lambda=1}$ describes the torque produced by the air flow through the throttle assuming that the spark advance is zero ($\eta_{SA}=1$) and the air-to-fuel ratio is an ideal 14.7:1, or $\lambda=1$ ($\eta_{\lambda}=1$). $T_{req\lambda=1}$ is calculated at a constant rate of 120 samples/second, or 8 ms per sample. Changing the amount of air changes the engine torque at a relatively slow rate because of a 35 millisecond delay through the manifold between the throttle valve and the engine cylinders. The crank-synchronous efficiencies, η_{SA} and η_{λ} , determine the effects of spark advance and fuel injection on the engine torque. They are calculated at a variable rate determined by the rotational speed of the engine. This rate can vary from 120 ms per sample at 1000 RPM to 20 ms per sample at 6,000 RPM. This breakdown of the torque into fixed rate and crank-synchronous components allows the coordinated control of both the throttle (fixed rate component) and the spark advance and fuel injection (crank-synchronous components) using a common numerical quantity even though the individual components are sampled at different data rates.
- The torque-based engine controller uses a torque demand manager to calculate a total requested torque T_{req} from a combination of the driver requested torque, T_{Driver} , and all the other torques requested by the vehicle, $T_{Vehicle}$, as listed in Figure 4. This calculation of a total requested torque simplifies the design of the engine controller over other engine controllers based on air flow, making

it easier to add new vehicle functions that modify the torque produced by the engine such as cruise control or electronic stability control. This is why all auto manufacturers want to use a torque-based engine controller. The splitting of the total torque request T_{req} into target $T_{req\lambda=1}$, η_{SA} and η_λ components to command the actuators is done by dividing the total requested torque T_{req} by the actual values measured from engine operation. For example, $T_{req\lambda=1}$ is calculated by dividing the total torque T_{req} by $\eta_{SA}\eta_\lambda$ measured from engine operation. Similarly, the target value of η_{SA} is calculated by dividing the total torque T_{req} by the actual values of $T_{act\lambda=1}$ and η_λ .

3. All quantities in the engine controller are calculated using maps, or look-up tables. All maps are a function of the engine RPM. Two-dimensional interpolation is used to obtain map outputs associated with input parameter values lying in between the discrete values tabulated in the maps. Maps associated with air flow are as follows:
 - a. Engine torque map. This map translates the actual air charge or load from the MAP sensor into the actual torque $T_{act\lambda=1}$ produced by the engine with $\lambda=1$ and the spark advance = 0 ($\eta_\lambda=1$ and $\eta_{SA}=1$). This map is created, or calibrated, by operating the vehicle on a dynamometer and recording the torque produced by the engine for various values of applied air charge. The actual torque $T_{act\lambda=1}$ is used to determine the new target values of η_λ and η_{SA} .
 - b. Inverse engine map. This map translates the total requested torque $T_{req\lambda=1}$ into a target air charge or load for the cylinders. This map is the functional inverse of the engine torque map. This means that the two maps applied successively should give the value 1. Another way to say this is that the inverse map contains the same data as the engine torque map, but the inputs and outputs of the two maps are interchanged. This map is created using development software to obtain the functional inverse of the engine torque map.
 - c. Driver demand map. This map translates the accelerator pedal position into the driver's demand for torque, T_{Driver} . This map is created from the engine torque map by replacing the actual air charge input with the accelerator pedal position sensor input, and then modifying the linearity of the input scale to obtain a throttle response for the vehicle that is satisfying to most drivers. This map essentially translates the response of the actual engine into the response of an ideal engine that the driver finds more interesting to drive.
 - d. Air charge to throttle opening map. This map translates the target air charge or load into a target throttle opening command that gets sent to the PID controller. Its function is merely one of translation of units from air charge to throttle opening.
4. When the torque-based engine controller of Figure 2 is used with the plant of Figure 1, two loops are generated:
 - a. RPM loop. This is the loop from the inverse engine map \Rightarrow air charge to throttle opening map \Rightarrow { PID controller \Rightarrow battery voltage correction \Rightarrow PWM controller \Rightarrow H-bridge \Rightarrow throttle motor \Rightarrow throttle valve \Rightarrow air flow \Rightarrow engine \Rightarrow crankshaft sensor \Rightarrow RPM conversion } \Rightarrow inverse engine map.
 - b. Actual torque loop. This is the loop from the inverse engine map \Rightarrow air charge to throttle opening map \Rightarrow { PID controller \Rightarrow battery voltage correction \Rightarrow PWM controller \Rightarrow H-bridge \Rightarrow throttle motor \Rightarrow throttle valve \Rightarrow air flow \Rightarrow mass air flow (MAF) sensor } \Rightarrow engine torque map \Rightarrow inverse engine map.

The paths inside the braces define the plant that is being controlled. Both loops have the same electronic throttle actuator as part of their path.

5. Engineering control theory teaches the following about the design of this torque-based controller:
 - a. The inverse engine map is a feed-forward controller. Proper operation of a feed-forward controller requires that the inverse map must be the exact inverse of the process that is being controlled. This means that the RPM or actual torque $T_{act\lambda=1}$ that comes back to the inverse map must be the same RPM or actual torque $T_{act\lambda=1}$ that the inverse engine map used earlier to produce the throttle opening. The process in this case is the plant shown in Figure 1, which includes the electronic throttle actuator. If this plant changes in any way after the inverse map has been created, then the inverse map will no longer represent the changed process. In this case the controller will generate control errors that can lead to undesirable consequences.
 - b. The two loops in comment 4 above are not intended to be control loops. This follows because the inverse map controller is a feed-forward controller. In this case there is no feedback required because the feed-forward controller is assumed to already know the value of the engine RPM and torque coming back to it because they should not change from the values used to calculate the inverse map output in the first place. The values from these two loops are used only as parameters to select the proper map inputs for a given map output. The parameters are used only once for each new map input $T_{req\lambda=1}$.
 - c. Let us define the loop gain as the value of the RPM or actual torque $T_{act\lambda=1}$ coming back to the inverse map divided by the value of the RPM or actual torque $T_{act\lambda=1}$ used to calculate the output of the inverse map originally. Then control theory teaches:
 - i. Both loop gains must be =1 for normal controller operation. This is just another way of saying that the inverse engine map is the exact inverse of the process being controlled. This must be the case to keep the engine controller happy and free from errors.
 - ii. If either loop gain is <1 , then less actual torque $T_{act\lambda=1}$ and/or lower RPM will be produced on each cycle through the loop, and the process will spiral down to a minimum engine torque and/or a minimum engine RPM. This can happen if:
 1. A smaller diameter throttle body is used than the one tested on the dynamometer (recurring problem).
 2. A MAP sensor having a lower gain is used than the one tested on the dynamometer (recurring problem).
 3. The values in the inverse engine map and the engine torque map are modified by tuning enthusiasts who want to get more power out of their engines (recurring problem).
 4. The supply voltage of the throttle motor decreases and no battery voltage compensation is used to correct for this condition (intermittent problem depending upon battery charge condition).
 - iii. If either loop gain is >1 , then more actual torque $T_{act\lambda=1}$ and/or higher RPM will be produced on each cycle through the loop, and the process will run away to produce a maximum engine torque and/or a maximum engine RPM. This can happen if:
 1. A larger diameter throttle body is used than the one tested on the dynamometer (recurring problem).

2. A MAP sensor having a higher gain is used than the one tested on the dynamometer (recurring problem).
 3. The values in the inverse engine map and the engine torque map are modified by tuning enthusiasts who want to get more power out of their engines (recurring problem).
 4. Battery voltage compensation is used for the electric throttle motor, but an incorrect compensation coefficient is used because the battery voltage was sensed while a negative voltage spike was present (intermittent problem).
- iv. Mixed loop gains. It is possible to have different loop gain conditions in different parts of the inverse engine map. For example, one might have the loop gain >1 at higher engine RPMs but a normal loop gain at low engine RPMs. Or one might have a loop gain >1 at high requested torques $T_{req\lambda=1}$ but a normal loop gain $=1$ at lower requested torques. Mixed loop gains can happen when tuning enthusiasts increase the values in the inverse engine map without reducing the corresponding values in the engine torque map to keep the total loop gain equal to unity.

Figures 1 and 2 provide enough detail to allow one to simulate the operation of a torque-based engine controller with an electronic throttle. We will now describe this simulation.

III. Simulation of the Torque-Based Engine Controller With an Electronic Throttle

In order to do this simulation one must know how the efficiencies η_{SA} and η_{λ} depend upon spark advance and λ . These efficiencies are shown in Figures 3 and 4.

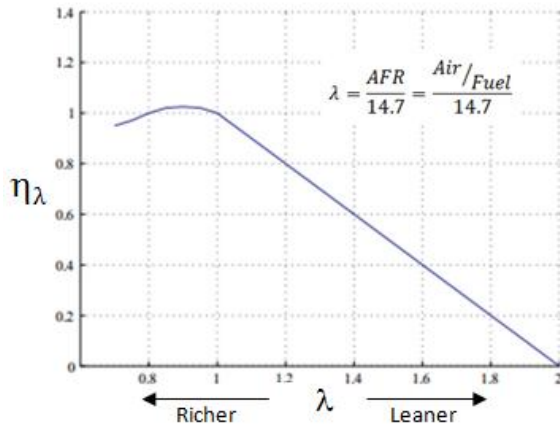

Figure 3. Lambda efficiency

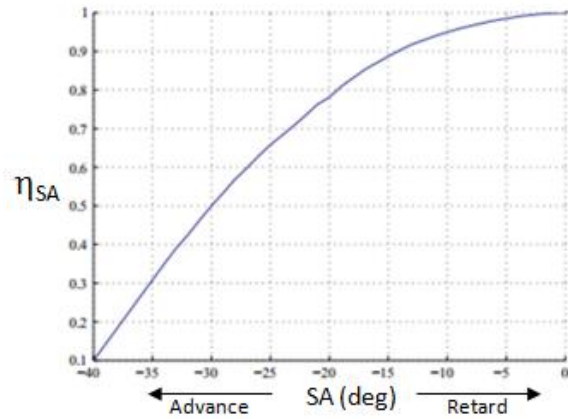

Figure 4. Spark advance efficiency

- A. Simulation of normal controller operation (loop gains =1). In this case the actual air charge equals the demanded air charge.
1. Since the inverse engine map is the exact inverse of the engine torque map, then actual air charge = target air charge implies the actual torque $T_{act\lambda=1}$ = the requested torque $T_{req\lambda=1}$.
 2. Since the actual air charge = target air charge, then the efficiencies η_{SA} and η_{λ} do not change. The engine continues to operate in a stable mode.

- B. Simulation of abnormal operation (loop gains <1). This condition can result if battery voltage compensation is not present to compensate for the decrease in throttle motor torque with decreasing battery voltage.
1. Assume a fixed requested idle-up torque T_{Vehicle} into the inverse engine map that is typical of an air conditioner pump load.
 2. A smaller throttle opening at lower battery voltage implies the actual air charge decreases.
 3. A smaller actual air charge implies the actual torque $T_{\text{act}\lambda=1}$ decreases.
 4. A smaller actual torque $T_{\text{act}\lambda=1}$ into the synchronous input to the spark advance conversion implies the efficiency η_{SA} increases.
 5. A larger efficiency η_{SA} implies the spark retards, which causes the engine speed to decrease.
 6. A larger efficiency η_{SA} into the fixed rate input to the inverse engine map causes the requested torque $T_{\text{req}\lambda=1}$ to decrease.
 7. A smaller requested torque $T_{\text{req}\lambda=1}$ causes the target air charge to decrease.
 8. A smaller target air charge implies the target throttle opening decreases.

Comparing step 8 to step 2 implies a runaway condition which results in the throttle valve closing completely, causing sudden stalling because the engine does not produce enough torque to satisfy the air conditioner load. This runaway condition caused by the throttle motor torque decreasing with decreasing battery voltage shows that battery voltage compensation of the PWM duty cycle to the throttle motor is essential to prevent sudden stalling of the engine under low battery voltage conditions. This proves that battery voltage compensation must be present in all torque-based throttle controllers. It also proves that a loop gain different from unity can create runaway problems for a torque-based engine controller.

- C. Simulation of abnormal operation (loop gains >1). This condition can result if battery voltage compensation of the throttle motor is present, but the compensation coefficient is incorrect because the battery voltage was sensed while a negative-going voltage spike was present on an otherwise normal DC battery voltage.
1. Assume a fixed requested idle-up torque T_{Vehicle} into the inverse engine map that is typical of an air conditioner pump load.
 2. A larger throttle opening implies the actual air charge increases.
 3. A larger actual air charge implies the actual torque $T_{\text{act}\lambda=1}$ increases.
 4. A larger actual torque $T_{\text{act}\lambda=1}$ into the synchronous input to the spark advance conversion implies the efficiency η_{SA} decreases.
 5. A smaller efficiency η_{SA} implies the spark advances, which implies that the engine speeds up.
 6. A smaller efficiency η_{SA} into the fixed rate input to the inverse engine map implies the requested torque $T_{\text{req}\lambda=1}$ increases.
 7. A larger requested torque $T_{\text{req}\lambda=1}$ implies the target air charge increases.
 8. A larger target air charge implies the target throttle opening increases.

Comparing step 8 to step 2 implies a runaway condition which results in the throttle valve opening to its maximum value, causing sudden acceleration with maximum engine torque. Along with this, the efficiency η_{SA} decreases to its minimum value, which implies that the spark advances to its maximum value, and the engine speeds up to its maximum RPM. This increase of the engine torque along with the increase in engine RPM seems at odds with the author's previous paper in which the author contends that the increase in engine RPM without a decrease in engine torque can explain why the engine speed increase is not slowed down by the load of the transmission on the engine. But we are not finished yet with the simulation, having looked at only one of the two loops present (the actual torque loop).

Let us now look at what happens to the RPM loop when its loop gain is >1 . This also happens when the compensation coefficient is incorrect as a result of the battery voltage being sensed while a negative-going voltage spike was present on an otherwise normal DC battery voltage. In this case:

1. Assume a fixed requested idle-up torque T_{Vehicle} into the inverse engine map that is typical of an air conditioner pump load.
2. For a given engine RPM the inverse engine map will produce a corresponding target air charge.
3. The target air charge will be translated into a corresponding throttle opening command to the PID controller.
4. As a result of the incorrect compensation coefficient, the throttle opening command to the electronic throttle motor will be increased, causing a larger-than-normal amount of air into the engine.
5. As a result of the larger-than-normal amount of air into the engine, the engine RPM increases.
6. A higher engine RPM to the inverse engine map causes the target air charge it produces to increase even though the input torque to the inverse map stays the same.

Comparing step 6 to step 2 implies a runaway condition in which the engine RPM increases to its maximum value with little increase in the engine torque. This corresponds to the case that the author analyzed in his previous paper.

Now, if we look at the results of simulating both loops, we see that a race condition exists when both loop gains are >1 . The winner of the race is the loop with the faster time constant. This will be the RPM loop because this loop is being traversed at a faster rate as noted in the inset to Figure 2; namely, a constant 12 ms per sample for the fixed rate RPM loop which is 10 times faster than the varying 120 ms to 20 ms for the crank-synchronous actual torque loop, which depends on engine speed. Therefore, the engine RPM will increase rapidly with little engine torque produced as a result of the engine RPM loop increasing first, followed immediately by an increase in engine torque as a result of the engine torque loop increasing later.⁶ This all happens within a second or two, even though the driver's foot is off the accelerator. And to make matters worse, this sudden increase in engine speed and engine torque happens from a stop, which means that the engine torque gets multiplied by the gear ratio active in first gear or reverse gear, to produce the final torque to the wheels. In first gear or reverse gear this gear ratio is a factor of 4 to 5, which means that the torque to the wheels is the maximum engine torque times a factor of 4 to 5. This is why it is so difficult to stop the vehicle under these conditions, and why vehicles undergoing sudden acceleration can easily spin the tires, jump over curbs, and crash through brick walls and storefronts.

It is commonly stated that the brakes will always override the engine in any vehicle to allow a normal stop, even at the maximum accelerator pedal position. But this statement assumes that the transmission is operating normally, which means the gears will shift automatically to lower ratios as the vehicle speed increases. In higher gears the gear ratio is less than a factor of 4 to 5, being more like 2 to 3. This means that the torque to the wheels is lower in higher gears, making it easier to stop. Instead of simulating stopping during sudden acceleration by applying the brakes while the accelerator pedal is pressed down all the way, one should do the simulation with the transmission placed in the lowest gear instead of allowing it to shift automatically as it does while in drive. Then the torque to the wheels will remain the same factor of 4 to 5 times the maximum engine torque as it is during sudden acceleration.

The situation gets even worse when the vehicle has a start button instead of a conventional ignition switch, and the driver must hold the start button down for up to five seconds before the CPU decides to process the stop command while it is controlling a runaway engine. And in some vehicles it is difficult to put the transmission into neutral because the transmission is electronically operated, and the CPU must again decide to process the shift command while it is controlling a runaway engine. No wonder that drivers involved in sudden acceleration incidents feel that the auto manufacturers are conspiring against

them when they are accused of pressing on the accelerator pedal instead of the brake pedal when this occurs. For lack of any other explanation known to them, some drivers might actually believe that they pressed the accelerator pedal by mistake when they really had their foot on the brake. After all, admitting that one pressed the accelerator pedal by mistake can make the driver appear to be a responsible citizen and not seem an idiot who claims that a seemingly impossible event has happened.

IV. Experimental Evidence for Sudden Acceleration Caused by Low Battery Voltage

Experimental evidence that supports the author's theory of sudden acceleration has been obtained recently by a research team at the National Forensic Service in Seoul, Korea. This organization is the Korean government's official automobile accident investigation team in Korea, and it has been looking into the cause of the epidemic of sudden acceleration incidents in Korea for the last several years. Their results show that the electronically operated throttle valve in a late model car with electronic throttle can be made to open to the maximum opening position by voltage fluctuations of 14 to 7 volts on the battery supply line without pressing on the accelerator pedal. Their results were described in an oral presentation given at the World Forensic Festival 2014 meeting in Seoul, Korea on October 12-18, 2014. An abstract of their presentation appears in the published abstract book for the meeting.⁷ This abstract is reproduced in its entirety in Figure 5 below. A paper describing their complete findings has been submitted to an international journal and will be published soon after going through the peer review process.

O 05-1

**EXPERIMENTAL STUDY OF REAPPEARANCE FOR
SUDDEN ACCELERATION INCIDENTS**

Sungji Park

*Forensic Engineering, National Forensic Service, Seoul, Korea
(South)*

Recently, as Electronic Control System has installed in normal automobiles, the sudden unintended acceleration comes to big issues around the world and the cause of this mysterious acceleration is not verified yet. This kind of study was carried out 10 years ago but it treated mechanical malfunction mainly and electrical-magnetic influences.

At this time, we focused on electronic system including electrical short on wire and sensor, and fluctuation on voltage etc.

The input voltage of ECU (Electronic Control Unit) was fluctuated from 7V to 14V periodically and the all of the engine data like throttle valve position, acceleration position, engine RPM, brake pressure and maximum torque of wheel were recorded.

As results of this study, we found that the periodical low voltage could make the throttle valve fully open and the car would reach the maximum performance condition. So, the unintended acceleration could happen without pressing acceleration pedal.

Figure 5. Abstract of an oral presentation at the World Forensic Festival 2014 meeting in Seoul, Korea on October 12-18, 2014

V. Related Evidence from the Automobile Engine Tuning Community

There are several communities of automobile engine tuning enthusiasts on the Internet who discuss their experiments on tuning the maps in their automobile ECUs with the goal of achieving higher engine performance (i.e., greater torque).⁸ They share details on engine controller design and operation and report on the results obtained when specific map modifications have been made. Their results show that modifications to the maps can cause changes in engine performance such as surging, lurching, and even a runaway condition which sound remarkably similar to the descriptions of sudden acceleration provided by drivers involved in such incidents. The following is a short description of some of their findings.

1. If the inverse engine map (KFMIRL) is increased, but the engine torque map (KFMIOP) is left unchanged, then one gets surging, lurching, and maybe even a runaway condition. Therefore, they have found experimentally that increasing the inverse engine map (KFMIRL) requires a corresponding decrease in the engine torque map (KFMIOP). We can explain this by the fact that control theory requires the product of the two maps to equal unity in order to have loop stability.
2. Increasing the values in small areas of the inverse engine map (KFMIRL) map can cause problems with surging at specific engine speeds and not at others. This can be avoided by changing all the values in the engine torque map (KFMIOP) map by the same multiplicative constant.
3. Increasing the inverse engine map (KFMIRL) too much can cause intervention.
4. Intervention can be suppressed by changing other maps which set the amount by which the actual torque can deviate from requested torque
5. We can also add here that the engine torque map (KFMIOP) should represent the actual engine torque as closely as possible because it is in parallel with actual engine operation, providing the actual torque and efficiencies to the inverse engine map (KFMIRL) while the actual engine is providing the RPM input. Therefore, if the engine torque map (KFMIOP) is changed too much in the process of trying to reduce its values to correspond to higher values in the inverse engine map (KFMIRL) (i.e., to keep the product of the two maps equal to one), then the engine RPM and the outputs of the engine torque map (KFMIOP) can get out of sync, and the controller may cause the engine to behave abnormally. This situation should be avoided.

VI. Fail-Safe Measures in a Torque-Based Engine Controller

Automobile manufacturers will respond to the simulation results and experimental data reported in this paper by stating that a runaway condition is only a conceptual possibility that is not encountered in the real world because fail-safe measures are present which prevent it from happening. Therefore, we now take a look at the fail-safe measures present in the Bosch torque-based engine controller.

In the Bosch torque-based controller fail-safe measures are referred to as intervention. These intervention measures are measures that modify the engine performance and are distinguished from setting an OBD-II fault code, which may happen along with some intervention measures but not others. In order to discuss the intervention measures present in the Bosch torque-based controller, it is helpful to use the same terminology that Bosch uses for its controller functions. This terminology is shown in red in Figure 6. In Figure 6 another map has been added that is used only for intervention control; namely, the torque limit map KFMIZUFIL.

The Bosch torque-based controller places two limits on the engine torque produced. A load limit prevents the target air charge or load $rlsol$ from being greater than some maximum air charge or load $rlmax$. This prevents the driver-demanded torque $mrfa$ from exceeding a maximum torque value $mimax$ obtained from

the maximum air charge or load $rlmax$ by using the map KFMIOPI. The maximum air charge $rlmax$ can represent either the true maximum air charge associated with the maximum torque that the engine can put out, or some artificial maximum air charge that limits the engine torque to some artificial limit, like a governor. This maximum air charge $rlmax$ is provided by the function LDRXN. The values of $mrfa$ obtained after the limit $mibas$ has been applied are referred to as $mifa$.

A second limit is placed on the total actual torque $mibas$ that the engine produces, which can vary with driver demand. This limit is stored in the torque limit map KFMIZUFIL, which is accessed by the output of the accelerator pedal position sensor $wped_w$. This map produces the engine torque limits $miszul$ to which the actual engine torque $mibas$ is compared. In this case, $mibas = m_{act\lambda=1} * \eta_{SA} \eta_{\lambda}$, so it includes the efficiencies for spark advance and λ . It should be noted that the torque limits provided by the torque limit map are merely estimates of maximum engine torque allowed under various conditions of RPM and $wped_w$. These estimates are not defined anywhere nor are they the same for different values of RPM and $wped_w$.

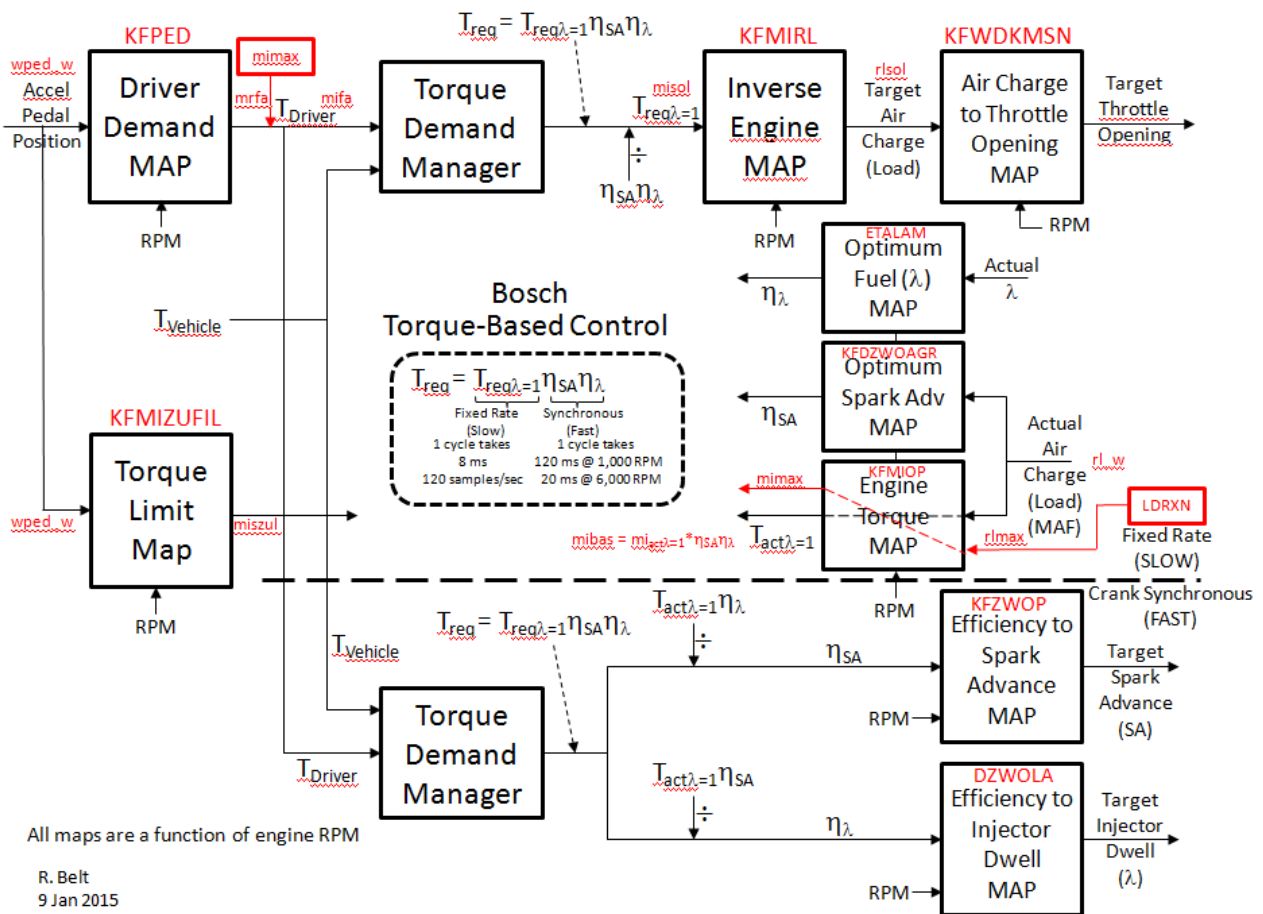

Figure 6. Bosch torque-based controller showing functions associated with intervention

As long as these two conditions are met, the engine controller operates normally. If either condition is violated, then intervention occurs. Two types of intervention can occur. If the violation is mild (<5% error), then engine timing is cut by decreasing the spark advance. If the violation is major (>5% error for 1 second or more), then power to the electronic throttle is cut, and the throttle defaults to the limp-home mode. These conditions and types of intervention are summarized in Table 1.

Table 1. Intervention limits and types

Normal Operation	Normal	Intervention for Abnormal Operation (Failsafes)	During Intervention
$mrfa < mimax$ (load limit) and $mibas < miszul$ (torque limit)	$mifa$ follows $mrfa$ $mizsol$ follows $mibas$	Level 1 intervention \Rightarrow timing cut or Level 2 intervention \Rightarrow limp home	$mifa$ follows $mimax$ $mizsol$ follows $miszul$

Note: mizsol = values in misol after timing intervention

Now this sounds like it should prevent sudden acceleration from occurring because the throttle will go into the limp-home mode if a runaway condition in the controller causes the engine torque to exceed the limits $miszul$ stored in the map KFMIZUFIL. There is one exception to this rule, however. We know that when the engine is at idle with the accelerator pedal released, even though the actual torque produced by the idle mode controller is greater than the torque demanded by the driver (zero), no intervention takes place or else the engine will go into the limp home mode. Therefore, intervention must be suppressed when the engine is in the idle mode with the accelerator pedal released. Can this be a hint of what causes no intervention to take place during a runaway throttle condition?

Let's take a closer look at what happens in the idle mode when an air conditioner idle-up occurs. Figure 7 shows a typical inverse engine map. Figure 8 shows a more detailed view of this inverse engine map in the region of low torque and low RPM.

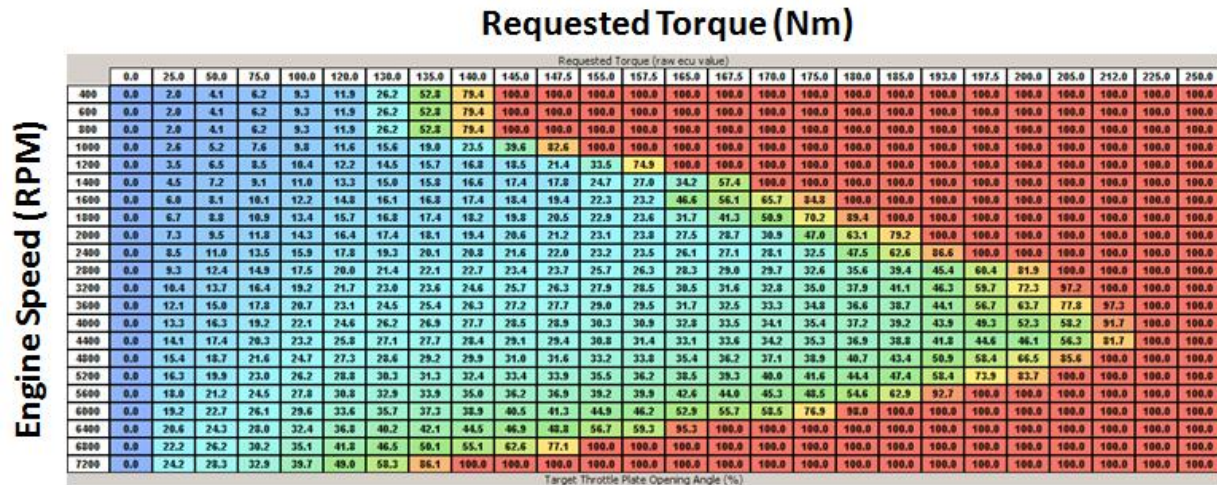

Figure 7. Typical inverse engine map providing a target throttle opening in response to a requested torque and engine speed

In Figure 8 the horizontal lines at 0, T_1 and T_2 represent the first three columns of numbers in the inverse engine map of Figure 7. Throttle openings for map values in between these horizontal lines can be found by linear interpolation. This provides a continuous range of torque values between T_1 and T_2 . Between 0 and T_1 , however, the torque values are continuous only above a threshold value, and are zero below that value. The zero torque values below the threshold are used to transfer engine control from an open loop torque mode controller, which uses the inverse map for control above the threshold, to a closed loop idle mode controller based on engine speed below the threshold value. This happens whenever the driver takes his foot off the accelerator pedal.

In the lower left hand corner of Figure 8 we show the normal idle condition at 800 RPM. The torque it produces lies below the threshold value, and is considered to be zero. If the air conditioner compressor turns on, then it puts a load on the engine which causes the engine to slow down and possibly even stall unless the engine speed is increased to generate more torque to offset the compressor load. This air conditioner idle-up point is shown by the second black dot in Figure 8. It has a higher torque value T_{AC} and a higher engine speed (~ 1800 RPM) than the normal idle point of 800 RPM.⁹ Since the engine should remain in the idle mode while this AC idle-up is occurring, the manufacturer adjusts the threshold value to lie above this T_{AC} value by some arbitrary safety factor δT_{AC} .

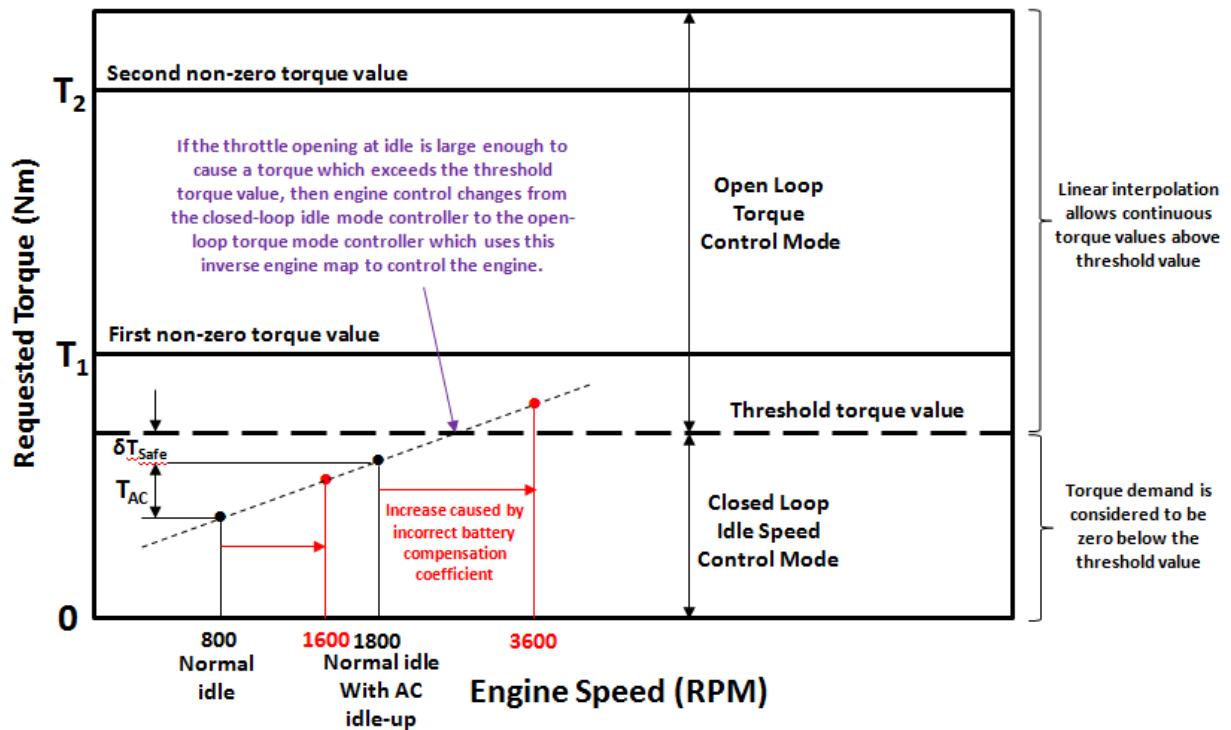

Figure 7. Detail of inverse engine map showing how an idle-up caused by the air conditioner pump turning on can cause a transition from the idle mode controller to the torque mode controller only when the throttle motor gain is increased above a threshold by an incorrect battery compensation coefficient

Now, if a negative voltage spike occurs while the battery voltage is being read, then an incorrect battery voltage compensation coefficient will be produced that causes the throttle motor to have a higher gain than normal. This will cause the throttle opening to be larger than the target throttle opening provided by the inverse engine map, which will increase the engine torque above the value desired by either the driver or the idle mode controller. This increased gain in the throttle motor can be a factor of 0 to 10 or more. Let's assume for the moment that the increase is a factor of two, which results from negative-going voltage spikes of about 6 volts. If the engine is idling normally at 800 RPM, then when an incorrect compensation coefficient is applied the idle speed will increase to about 1600 RPM, as shown by the first red dot in Figure 8. The engine torque will also increase, but will stay below the threshold value. Now, let's assume that the air conditioner compressor is on, and the engine is in the AC idle-up mode. If the same incorrect voltage compensation coefficient is now applied, then the engine speed will increase from about 1800 RPM to about 3600 RPM. The engine torque will also increase, and in this case it may exceed the threshold value because the normal AC idle-up torque value lies so close to the threshold value, as shown by the second red dot in Figure 8 (it differs by only the small safety factor δT_{AC}). When

the engine torque exceeds the threshold value, engine control will change from the idle mode controller to the torque mode controller. And since the inverse engine map in the torque mode controller is not calibrated for the higher throttle motor gain created by the incorrect voltage compensation coefficient, a runaway throttle condition will result.

Now the interesting thing about the preceding scenario is that the engine started out in the idle mode in which the actual engine torque exceeded the driver demanded torque, but no intervention occurred because intervention is suppressed in the idle mode with the accelerator pedal released (or else the limp home mode will always occur in idle). Then a voltage spike caused the engine torque to increase above the threshold value. But the circuitry that suppresses the intervention during idle knows nothing about this voltage spike. Therefore, it thinks that the idle mode controller remains in control, and continues to suppress any intervention even though engine control has really changed to the torque mode controller. This, then, is the reason for no intervention occurring. In short, the intervention control circuitry thinks the idle mode controller remains in charge and suppresses intervention, even though the torque mode controller is really in charge and undergoing a runaway condition as a result of an incorrect compensation coefficient.

It is worthwhile to call attention here to another problem associated with sudden acceleration beyond the lack of intervention. This is the problem that many drivers have claimed that they had their foot on the brake, yet the EDR readout shows that the brake pedal has not been applied. Now, it is interesting to note that the brake signal is treated differently than the other three signals to the EDR; namely the RPM, accelerator pedal position, and vehicle speed signals. The last three signals all are sampled routinely once every second. But the brake pedal signal is not sampled routinely once every second even though it could be. Instead, manufacturers have designed the controller so that the brake pedal signal is reported only when its value changes from the previous value. This means that the brake signal value cannot be sent to the EDR regularly by a synchronous task like the other three signals, but must have a special task to do so that is activated by a CPU interrupt. Perhaps when the engine is at its maximum RPM the controller CPU is so busy with maintaining normal engine functions that it cannot respond to a lower priority CPU interrupt like a brake signal communication task.

It is also interesting to note that pressing the start button for five seconds to stop the engine, and shifting gears with an electronically operated transmission, are also tasks that generate an interrupt to the CPU. In vehicles where the CPU handling these functions is the same as the CPU handling the normal engine functions, it may be possible that when the engine is at its maximum RPM the controller CPU is so busy with maintaining normal engine functions that it has no time to respond to these two interrupts because they have a lower priority. This could explain the situation that some drivers have noted whereby it is impossible to shift into neutral or to turn off the engine during a sudden acceleration incident.

Further research is required to explain the absence of brake activation in the EDR and the failure to shift gears or turn off the engine in some vehicles during a sudden acceleration event. However, it appears clear enough from the simulation results presented in Section III and from experimental evidence provided by the Korean National Forensic Service in Section IV, as well as from similar behaviors noted by tuning enthusiasts in Section V, that the root cause of sudden acceleration has been found. And it is not with the driver. NHTSA and the automobile manufacturers should stop claiming that sudden acceleration is caused by the driver and should start looking at the electronic throttle controller design for the root cause of sudden acceleration and how to stop this epidemic of runaway cars before more people get killed.

VII. Testing of Automobiles for Sudden Acceleration

This section provides a test plan for testing automobiles to assess whether they are subject to sudden acceleration caused by the mechanism reported in this paper. This test plan has been submitted to the National Highway Traffic and Safety Administration (NHTSA) on November 1, 2014, in response to their request for comments on Automotive Electronic Control Systems Safety and Security, Docket No. NHTSA–2014–0108. A copy of the letter of transmittal is shown in Appendix 1. The following paragraphs are the complete response provided by the author.

EMI test plans for automobiles conventionally place a lot of emphasis on the stimuli for the test, but do not always specify the state of the vehicle during the test. Therefore, the vehicle is usually a fresh new vehicle off the assembly line, and it is tested while idling in PARK or NEUTRAL, which is convenient for the tester. This makes the EMI test results typical of a new vehicle off the showroom floor, but not of an average vehicle that has been on the road for several years. It is desired that EMI tests be conducted that produce results more typical of an average vehicle on the road. This means that EMI tests should be done using worst-case operational scenarios and not the best-case operational scenarios applicable to new vehicles only.

For example, it is known that a battery ages with time and use, undergoing deterioration of its state of charge, such that it must be replaced after approximately three to five years. It is also known that the battery acts like a large capacitor on the 12V supply line, attenuating any voltage spikes produced by the inrush currents of electric motors and other accessories turning on. Therefore, as the battery ages, it becomes less effective in attenuating these voltage spikes, and the likelihood increases that these voltage spikes will cause problems with the vehicle electronics. Therefore, all EMI tests should be performed for a worst-case scenario with a weak battery on the vehicle, e.g., one whose state of charge results in a voltage of 11.0 volts or less, in order to be more typical of a vehicle on the road.

The operating state of the vehicle during the EMI test should also be specified as a worst-case scenario. For example, it is well known that the PID parameters of the electronic throttle control loop are ten times more sensitive when the transmission is in DRIVE or REVERSE than they are when the transmission is idling in PARK or NEUTRAL. Therefore, all EMI tests should be performed while the engine is running with the transmission in either DRIVE or REVERSE, in order to be more typical of a vehicle on the road. There are also times while the vehicle is operating when it is more sensitive to EMI stimuli than other times. For example, while the A/D converter in the ECU is sampling the 12V battery supply line in order to determine how to compensate the PWM command to the throttle motor for low throttle motor supply voltage, the sampling process is more sensitive to negative-going voltage spikes from inrush currents on the 12V supply line. Such negative-going voltage spikes can produce an error in reading the true DC supply voltage which causes the incorrect compensation of the throttle motor command. In fact, the incorrect compensation of the throttle motor command due to negative-going voltage spikes will cause the throttle to become more sensitive (i.e., producing a larger throttle opening for the same size accelerator input), leading to an increased engine response as a result of ordinary idle-up commands. This is the basis of a theory of sudden acceleration proposed by this author, which can be found by reading his papers at <http://www.autosafety.org/dr-ronald-belt%E2%80%99s-sudden-acceleration-papers>. Therefore, all EMI tests involving conducted currents and voltages should inject the negative-going voltage spikes at a time when the battery voltage is being sampled, in order to be more typical of a vehicle on the road.

Now, automobile manufacturers do not specify the time when the battery voltage is being sampled for use in compensating the PWM command to the electronic throttle motor. They also do not provide this voltage for observation via the OBD-II port. This makes EMI testing during the A/D sampling time very difficult for anyone other than the original manufacturer. Therefore, in order to make it possible to do such EMI testing by NHTSA and by other independent laboratories, NHTSA should require all auto manufacturers to provide the following information:

1. How to read via the OBD-II port the variable value of the sampled battery voltage that is used when compensating the commands to the electronic throttle motor. If this sampled battery voltage is different for compensating the injectors, the variable valve timing (VVT-i) oil control valve (OCV), and the power steering assist motor, then tell how to read these voltages as well. If this voltage cannot be read via the OBD-II port, NHTSA shall require that it be done on all future model years.
2. When and under what conditions the battery voltage is sampled for use in compensating the commands to the electronic throttle motor. If this sampled voltage is different for compensating the injectors, the variable valve timing (VVT-i) oil control valve (OCV), and the power steering assist motor, then explain when and under what conditions the battery voltage is sampled for use in compensating these other functions. These times may vary with vehicle model and year, as well as with the driving pattern.
3. How to change the value of the sampled battery voltage in memory that is used for compensating the commands to the electronic throttle motor. If this sampled battery voltage is different for compensating the injectors, the variable valve timing (VVT-i) oil control valve (OCV), and the power steering assist motor, then explain how to change the value of the sampled battery voltage in memory that is used for these other functions. This capability to change the value in memory shall be used only for conducting EMI tests.

Armed with the above information from the auto manufacturers as required by NHTSA, one can then do the following EMI tests.

- 1. Sudden acceleration susceptibility test #1 (Substituted Sampled Battery Voltage)**
 - a. This test shall be done with the drive wheels off the ground and with a weakened vehicle battery having a voltage of 11.0V or less.
 - b. Start the vehicle and put the transmission in DRIVE.
 - c. Using a scan tool on the OBD-II port, read the sampled battery voltage that is used to compensate the PWM command to the throttle motor.
 - d. Change the value of the memory location storing the sampled battery voltage to a lower value, such as 4 volts. This will change the compensation of the throttle motor command, causing the throttle to become more sensitive to all throttle inputs from the accelerator pedal and the idle system.
 - e. With the throttle in a more sensitive state, turn on the air conditioner. This will cause an idle-up in the engine RPM due to the air conditioner pump motor turning on. Note any changes which take place in the engine RPM.
 - f. With the throttle in a more sensitive state, depress the accelerator pedal a small amount to simulate a stuck accelerator pedal. The amount of depression should initially raise the engine RPM only a small amount. Leave the accelerator pedal depressed at this level and note any changes which take place in the engine RPM.
 - g. Repeat the above steps with different values between 12.5V and 0V written to the memory location storing the sampled battery voltage voltages.
- 2. Sudden acceleration susceptibility test #2 (External Throttle Motor Power Supply)**
 - a. This test shall be done with the drive wheels off the ground and with a weakened vehicle battery having a voltage of 11.0V or less.
 - b. The 12V battery power to the electronic throttle motor and to its sampling point shall be disconnected, and an external variable voltage supply shall be connected between that point and ground to operate the throttle motor. The external power supply shall be capable of supplying variable voltages at a current of approximately 10 amps or greater.

- c. With the external power supply set at 12.5V, start the vehicle and put the transmission in DRIVE.
- d. With the engine running and the transmission in DRIVE, reduce the voltage on the external power supply to 6V. Continue to operate it at 6V while monitoring via the OBD-II port using a scan tool the value of the sampled battery voltage that is used when compensating the commands to the electronic throttle motor.
- e. When the value of the sampled battery voltage on the OBD-II port reads 6V, raise the voltage on the external power supply to 12.5V. This will put the throttle in a more sensitive state than normal.
- f. With the throttle in a more sensitive state, turn on the air conditioner to induce an idle-up command. This idle-up command will create a larger-than-normal idle-up response. Note whether any long-term changes take place in the engine RPM.
- g. With the throttle in a more sensitive state, depress the accelerator pedal a small amount to simulate a stuck accelerator pedal and leave it depressed. Note whether any long-term changes take place in the engine RPM.
- h. Repeat the above steps for different external power supply voltages between 8V and 12.5V.

3. Sudden acceleration susceptibility test #3 (Simulated Voltage Spikes from Inrush Currents)

- a. This test shall be done with the drive wheels off the ground and with a weakened vehicle battery having a voltage of 11.0V or less.
- b. Start the vehicle and put the transmission in DRIVE.
- c. Inject negative-going voltage spikes on the battery supply line at the node where the battery voltage is sampled for compensation of the electronic throttle motor and at the time specified by the manufacturer as being when the battery voltage is being sampled. The goal is to have the injected inrush current waveforms overlap the sampling time of the 12V supply used for compensation of these accessories. The injected waveforms should be injected from a low impedance source, making the source an instantaneous current sink for the current from the battery node, thereby making the waveforms simulate the inrush currents produced by electric motors and other accessories powered by the same 12V supply line. The waveforms shall have durations of approximately 20 to 200 milliseconds and shall result in node voltages between 11.0V and 0.0V.
- d. Monitor the sampled compensation voltage via the OBD-II port using a scan tool. When a compensation voltage is read that is lower than the DC voltage of the “weak” battery, then the throttle motor will be in a more sensitive state.
- e. With the throttle motor in a more sensitive state, turn on the air conditioner to induce an idle-up command. This idle-up command will create a larger-than-normal response idle-up response. Note whether any long-term changes take place in the engine RPM.
- f. With the throttle motor in a more sensitive state, depress the accelerator pedal a small amount to simulate a stuck accelerator pedal and leave it depressed. Note whether any long-term changes take place in the engine RPM.
- g. Repeat the above steps for waveforms producing different node voltages between 11.0V and 0.0V.

Similar EMI tests can be performed for other purposes, such as the effect of EMI on the power steering assist motor, knowing how the supply voltage for this motor is compensated by a sampled battery voltage.

The NHTSA should immediately begin an engineering investigation of the theory advanced in this paper by sponsoring efforts to simulate and test engine controllers operating with electronic throttle systems. There is no need to precede this engineering investigation with a preliminary investigation because all automobiles with electronic throttles have a similar controller design with respect to using an inverse

engine map to control the electronic throttle, and this paper presents a preponderance of evidence to show that this controller design can cause sudden acceleration. NHTSA's investigation should specifically look into the operation of the engine controller while the electronic throttle duty cycle is compensated with an incorrect battery voltage compensation coefficient. This investigation should include the testing of actual automobiles according to the test plan of this Section, and may be performed either by NHTSA's laboratory or by an independent laboratory funded by NHTSA. The investigation should also include sponsoring the following types of simulations:

- a. A MatLab/Simulink or other software simulation of a torque-based engine controller controlling an engine with an electronic throttle that is more faithful and more quantitative than the simulation in this paper. This can be done by any of the following :
 - i. Company engineers responsible for engine controller design. All companies have engineers involved in this activity, as described by the following job description:

Engine Control System Calibration Engineer:¹⁰
In this position you will be responsible for the development and implementation of engine management control system strategies and diagnostics. Additionally, you will discuss and recommend calibration strategies with key stakeholders within the product development team to gain program consensus and set relevant program targets. You will represent application engineering in meetings with key stakeholders during the engine development process. You will also develop power train calibrations in the areas of electronic throttle control torque maps, throttle filtering, fuel mapping and shift spark timing as assigned while meeting product performance and timing targets.

Requirements: BS in mechanical, electrical, controls, or systems engineering from an accredited university. Utilization of sensors in feedback and feed-forward control strategies. Understanding of integrated power train control (torque characterization, engine/transmission interactions, power train optimization strategies). Good overall knowledge of internal combustion (IC) engines and engine control systems. Experience in controls theory and tools, modeling, simulation, development, testing, and validation. Experience with model-based development tools such as MATLAB or SIMULINK, engine calibration, and embedded software experience is preferred.
 - ii. University researchers involved in engine control systems.
 - iii. Government researchers involved in engine controller simulation. It is interesting that the U.S. Department of Energy has a Vehicle Technologies Program under the office of Energy Efficiency and Renewable Energy which performs Advanced Vehicle Technology Analysis and Evaluation by sponsoring contracts with various government laboratories, such as the National Transportation Research Center at Oak Ridge National Laboratory. Researchers at this research center have the simulation tools and the experience necessary to perform the simulation of a torque-based engine controller controlling an engine with an electronic throttle.
- b. A hardware-in-the-loop (HIL) computer simulation of a real ECU with a torque-based engine controller while using software to simulate the engine with its electronic throttle actuator and related sensors. HIL simulations of ECUs are routinely performed by all auto manufacturers.

VIII. Implications of the Results of This Paper

The following are some implications of the results of this paper.

1. Sudden acceleration is caused by a design fault by the auto manufacturers. Their error lies in not taking into account the effects of the noisy electrical environment in the vehicle on the battery voltage supply line and its effects on throttle controller design. Specifically, auto manufacturers did not take into account that negative-going voltage spikes on the battery supply line, which occur during the sensing of battery voltage, can cause an erroneous duty cycle compensation coefficient for the electronic throttle motor. Whether this failure to take into account the electrical environment was

done inadvertently because the designers failed to understand the electrical environment, or whether it was done knowingly as a cost-saving decision is immaterial. The fact is that the controller design is faulty and must be fixed by the auto manufacturer. And fixing this fault means fixing all the vehicles on the road as well as new designs still in development.

2. The design fault applies to all automobiles that use an inverse engine map to control the electronic throttle. The essential aspect of the torque-based engine controller that produces the sudden acceleration problem is the use of an inverse engine map to control the electronic throttle. Therefore, the results of this paper also apply to all automobiles that have engine controllers which use an inverse engine map to control the electronic throttle. This means that engine controllers which use air charge or other variables as the input to the inverse engine map instead of torque are also susceptible to causing sudden acceleration by the same root cause as the torque-based engine controller. It is important to know this because some auto manufacturers have used air charge or other variables to address the inverse engine map before changing to a true Bosch torque-based engine controller design. So how do we know if an auto manufacturer's engine controller design uses an inverse engine map to control the electronic throttle? The answer is that one can tell when the manufacturer advertises that the accelerator pedal versus engine torque characteristic is non-linear, or that it changes with engine RPM. And we can know an electronic throttle is present by checking the throttle valve design for the specific automobile model or engine of interest. This means that all makes and models of automobiles having an electronic throttle controlled by an engine controller using an inverse engine map are similar in design, and should be treated as similar designs in a court of law.
3. The design fault applies to vehicles in addition to automobiles that use an inverse engine map to control an electronic throttle. This means that vehicles including trucks, buses, motorcycles, and boats, as well as automobiles, are subject to the sudden acceleration of their engine operation as a result of their design. The key common factor here is the presence of an electronic throttle controlled by an inverse engine map. This explains reports of sudden unintended acceleration in motorcycles, such as Harley-Davidson, Honda, Yamaha, BMW, Buell, and other motorcycles, which started using electronic throttles in 2006. It may also explain the crash of an F1 racing car by Maria de Villota on July 3, 2012, which suddenly revved up from idle to its maximum RPM. Maria has since died from the massive head injuries incurred during this incident. In this case, F1 racing cars are known to use electronic throttles controlled by an inverse engine map.¹¹ Their throttles are usually run wide open during a race, with the engine speed modulated by changes in the engine timing instead of in the throttle opening. But the idle speed is regulated to about 8000 RPM by the throttle opening, and we know from our simulation that this throttle opening must be controlled by a compensation voltage or else the idle speed will reduce as the battery voltage falls and the engine will stall for lack of torque. Therefore, an incorrect compensation voltage can cause the idle speed to increase suddenly, sending the engine speed suddenly to its maximum RPM of 20,000 RPM, which is exactly what happened in the case of Maria de Villota. Investigators concluded that the problem likely arose in the anti-stall system used on the racer, which sounds very much like the problem described in this paper. It is interesting to note that another racing driver, Timo Glock, also experienced an open throttle condition on this same car during a race, and had to quit the race after the only way of controlling the condition was by slipping the clutch.
4. The design fault applies to engines in vehicles having manual transmissions as well as automatic transmissions.¹² However, with manual transmissions the clutch can be depressed to stop the engine torque from being delivered to the wheels, enabling the driver to control the sudden increase in engine torque. Since most trucks and buses have manual transmissions, this may be the reason why fewer sudden acceleration incidents have been reported in trucks and buses. Similarly, European drivers tend to prefer manual transmissions over automatic transmissions, so this may be the reason why

fewer sudden acceleration incidents have been reported in Europe. European sudden acceleration incidents have tended to involve vehicles with automatic transmissions.

5. The results of this paper explain how the engine speed can increase to a maximum immediately from idle, which cannot happen when the accelerator pedal is pressed suddenly to the floor. To understand this statement, the reader should click on the following links to look at videos of real sudden acceleration incidents, and listen for how rapidly the engine speeds up to its maximum RPM:
 - a. <https://www.youtube.com/watch?v=K77JR3vu210Lkjlksdfjlkds>, incident around a bus
 - b. <https://www.youtube.com/watch?v=pk2oLY1C0Fo>, car on Korean on-ramp
 - c. http://www.liveleak.com/view?i=4be_1358013428&comments=1&safe_mode=off, car in narrow Korean street
 - d. <http://blogs.wsj.com/drivers-seat/2012/05/14/korean-officials-probe-sudden-acceleration-case-video/?mod=e2fb> Daegu incident at 112 km/hr.

Now go out to your automobile and try the following experiment. With the engine idling in DRIVE or REVERSE and your foot off the brake, suddenly floor the accelerator pedal and note how fast the engine speed rises. It will not rise to a maximum immediately like the cars in the videos, no matter how fast you push down the accelerator pedal. Now, with the engine idling in PARK or NEUTRAL, suddenly floor the accelerator pedal and note how fast the engine speed rises. It will rise much faster, almost like the cars in the videos. The reason the engine speed rises faster in PARK or NEUTRAL than in DRIVE or REVERSE is that there is no load on the engine from the drive train while in PARK or NEUTRAL. This load is present when operating in DRIVE or REVERSE and must be overcome by the engine torque before the engine speed gets to a maximum, and as every drag racer and most drivers know. So how did the drivers in the videos get their engines to speed up immediately to a maximum RPM while in DRIVE or REVERSE? The answer is that they didn't do it by pressing on the accelerator pedal. Instead, Mother Nature¹³ found a way to make the engine speed increase while the driver's foot was off the accelerator pedal and without producing any engine torque, so there was no need for the engine torque to overcome the load caused by the drive train. The engine speed could then increase to a maximum RPM immediately. This paper describes how Mother Nature did it. This means that the simulations of sudden acceleration that some people have placed on the Internet, in which they floor the accelerator and then show that the brakes can overcome the engine acceleration, are wrong. They are wrong in two ways: 1) because the engine speed in their simulations increases much slower than in a real sudden acceleration incident, and 2) because the transmission will automatically shift into higher gears as the vehicle speed increases, causing the engine torque to the wheels to decrease as the higher gears provide a decreasing gear ratio. Real incidents are much worse than these purported simulations.

6. Brake throttle override is completely ineffective in preventing sudden acceleration by the electronic defect described in this paper. This is true because it is not necessary for the driver to have his foot on the accelerator pedal to have sudden acceleration occur. The sudden acceleration is caused solely by the electronic defect while the driver's foot is off the accelerator pedal, just like thousands of drivers involved in sudden acceleration incidents over the past decade have maintained. Confusion of the accelerator pedal for the brake pedal, or simultaneous application of the accelerator pedal and the brake pedal, are fictional explanations for sudden acceleration promoted by the auto manufacturers to avoid legal liability in a court of law.
7. The lack of intervention during sudden acceleration is caused by the intervention control circuitry thinking that the idle mode controller is in charge and suppressing intervention, even though the torque mode controller is really in charge and undergoing a runaway condition as a result of an

incorrect compensation coefficient. The following conclusions apply to this proposed explanation for the lack of intervention during a runaway open throttle condition:

- a. This explanation of non-intervention applies to all engine types in all vehicles from all manufacturers because all manufacturers use the same torque-based engine control system which relies on an inverse engine map that incorporates a torque threshold for the transfer of control between the idle mode controller and the torque mode controller. This means:
 - i. The same explanation applies to all auto manufacturers, including all models of vehicles from each manufacturer.
 - ii. The same explanation applies to all vehicle types, including automobiles, trucks, buses, motorcycles, boats, and F1 race cars.
 - b. The lack of intervention is independent of processor design or software implementation. It is caused entirely by the normal operation of the idle mode controller and how it interacts with the torque mode controller under the control of the inverse throttle map.
 - c. The lack of intervention explains the failure of the ECU to set an OBDII code during a sudden acceleration incident. If no intervention occurs (i.e., no fail-safe is triggered), then no OBDII code will be set.
 - i. The failure to set an OBDII code in vehicles of any type from any manufacturer is a further indication that the explanation of non-intervention is correct, and independent of processor design and software implementation, which should vary from manufacturer to manufacturer.
 - d. The lack of intervention in the idle mode controller may depend on the fact that the accelerator pedal is released. If so, this confirms the claims of many drivers that their foot was on the brake pedal and not on the accelerator pedal during a sudden acceleration incident.
 - e. This reason for non-intervention does not apply to the case where the accelerator pedal sticks at a small depression angle. In this case, a runaway throttle condition will occur if accompanied by an incorrect voltage compensation coefficient, but intervention will not be suppressed because the runaway condition does not originate while in the idle mode. Therefore, in this case, intervention will occur to switch the throttle into the limp-home mode. However, the intervention will occur only after a time period of 2 to 5 seconds. Many sudden acceleration events are over before this time delay can take place.
8. The results of this paper are more general than the Barr theory of sudden acceleration based on task death by stack overflow. The following aspects of sudden acceleration are not explained by Barr's theory. They are explained however, by the theory presented in this paper.
- a. Sudden acceleration in non-Toyota vehicles. Sudden acceleration has been observed in all makes and models of automobiles the world over.¹⁴ However, Barr's theory of task death caused by stack overflow was developed by looking at Toyota software only, and was accompanied by evidence showing that Toyota's software development processes were so deficient that they made Toyota look almost incompetent. It is difficult to conceive that the software development processes of all auto manufacturers are just as bad as those of Toyota. Given the variations that exist in CPU chip design and software coding, it is likely that some auto manufacturer has been able to avoid task death by stack overflow. Yet, sudden acceleration has been observed in all makes and models of automobiles the world over. So

some other cause of sudden acceleration must be present. The theory advanced in this paper explains sudden acceleration in all vehicles having electronic throttles.

- b. Sudden acceleration from a stopped position. A large percentage of sudden acceleration incidents start with the vehicle in a stopped position. However, Barr's theory of task death caused by stack overflow applies only to incidents in which the throttle gets stuck while traveling at a high vehicle speed. This is because when Task X dies, the theory assumes that the throttle PID controller, H-bridge, and electronic throttle motor continue to operate normally with the throttle opening command from Task X stuck at the value it had just before Task X died. Barr's theory of task death provided a good explanation of the sudden acceleration found in the Oklahoma case, where the Bookout car was traveling on a highway and could not be stopped after it turned down an exit ramp, leaving skid marks on the ramp. But it must be supplemented with another mechanism to explain how the engine speed increases when the sudden acceleration starts in a stopped vehicle position. This additional mechanism was the purpose of the full throttle bug (FTB), which Barr introduced later in the St. John MDL case. However, in that case the judge ruled out testimony of the full throttle bug because he said it was developed after the discovery phase of the trial was over. After the St. John case was settled out of court, the trial documents were sealed, so Barr is not allowed to discuss the full throttle bug publicly any more under an order of the court. Although it is possible that Barr's theory of the full throttle bug could be resurrected for use in another sudden acceleration case, it is unlikely this will happen because Toyota is settling all MDL cases out of court with the documents sealed. Therefore, it is unlikely that the full throttle bug will ever be discussed publicly, and will remain an undeveloped theory. Meanwhile, the theory advanced in this paper explains sudden acceleration from a stopped position as being caused by sensing of the battery voltage during a negative-going voltage spike, which produces an incorrect battery voltage compensation coefficient that increases the gain of the throttle motor making the torque-based engine controller become unstable and causing it to run away to a maximum engine RPM.
- c. Temporary surges, lunges, and lurches. Barr's theory of task death caused by stack overflow implies that the PID controller, H-bridge, and electronic throttle motor will continue to operate normally after Task X dies. The same implication follows when his theory is supplemented by the full throttle bug. Therefore, in both cases the engine will continue to run steadily at some RPM until the ignition is shut off. However, there are many sudden acceleration incidents reported under the name of surges, lunges, and lurches, in which the engine RPM rises a small amount, and then decreases back to its original value. These incidents cannot be explained by Barr's theory of task death caused by stack overflow, even when supplemented by the mechanism of the full throttle bug. These incidents can be explained by the theory advanced in this paper as being caused by an incorrect battery voltage compensation coefficient that increases the gain of the throttle motor, but which does not make the torque-based engine controller become unstable and cause it to run away to a maximum engine RPM because the idle-up is a short duration idle-up caused by some accessory and not a long duration idle-up caused by the air conditioner pump.
- d. The immediate increase in engine speed. This phenomenon was discussed in implication 5 above. Barr's theory cannot explain how engine speed can rise to a maximum RPM immediately while in DRIVE or REVERSE because his theory assumes that the throttle PID controller, H-bridge, and electronic throttle motor continue to operate normally after Task X has died. Therefore, when Task X dies, the effect on the throttle is exactly the same as when the driver presses the accelerator pedal all the way to the floor. The engine speed will increase at a slower rate because engine torque must overcome the load imposed by the drive

train. The theory of this paper explains that engine speed can increase more rapidly than normal because the fault does not immediately produce an engine torque that must overcome the load of the drive train.

- e. Low battery voltage can cause sudden acceleration. Experimental results from the National Forensic Service in Seoul, Korea, reported in section IV of this paper, show that the electronically operated throttle valve in a late model car with electronic throttle can be made to open to the maximum opening position by voltage fluctuations of 14 to 7 volts on the battery supply line without pressing on the accelerator pedal. This experimental data cannot be explained by the Barr theory, which is based on task death caused by stack overflow. Barr's full throttle bug may have an influence on whether the RPM changes from low RPM to high RPM, and this change may be affected by a voltage, but in his theory the low voltage does not cause the sudden acceleration. The probability of sudden acceleration is still caused by the probability of stack overflow, which is independent of voltage. The theory advanced in this paper explains that sudden acceleration is caused by sensing of the battery voltage during a negative-going voltage spike, which produces an incorrect battery voltage compensation coefficient that increases the gain of the throttle motor making the torque-based engine controller become unstable and causing it to run away to a maximum engine RPM.
- f. The preponderance of SUA incidents among elderly drivers. Statistical evidence verifies the sad fact that sudden acceleration from a stop happens more often to elderly drivers. Barr's theory has nothing to say about this fact because the probability of sudden acceleration occurring is determined by the probability of stack overflow, which is independent of the driver's age. But the theory advanced in this paper says that the probability of sudden acceleration occurring is related to the probability of a negative voltage spike occurring while the battery voltage is being sampled. And it is known that the amplitude of negative voltage spikes on the battery supply line increases with a decrease in battery charge (i.e., with a weak battery). Now, it is known that elderly drivers, many of whom are retired, make shorter trips with their vehicles than younger drivers, who work daily and must commute longer distances. Therefore, the batteries of elderly drivers will not get charged up as completely as those of younger drivers, and will tend to get weaker with time faster than those of younger drivers. This makes it more likely that negative voltage spikes will be found on the battery supply lines of elderly drivers, increasing the likelihood of producing a sudden acceleration incident.

The failure of Barr's theory to explain these aspects of sudden acceleration makes it questionable whether Barr's theory is a correct theory of sudden acceleration. On the other hand, the results of this paper provide an explanation for all of these phenomena.

IX. Conclusion

The Bosch torque-based engine controller for vehicles having electronic throttles has been described and simulated. Simulation shows that the Bosch engine controller can experience a runaway open-throttle condition when operating with a slightly higher throttle gain associated with an incorrect battery voltage compensation caused by sensing the battery voltage during a negative-going voltage spike on the battery supply line produced by one of the vehicle's accessory electric motors turning on. This runaway open-throttle condition has all the characteristics of sudden acceleration in automobiles, and can explain the sudden acceleration of all vehicles with electronic throttles worldwide. Approaches for testing automobiles for the runaway condition have been provided. Implications of the paper's results have been discussed.

Appendix 1.

Letter to NHTSA in Response to Request for Comments on the Safety and Security of Automotive Electronic Control Systems

1 November 2014

National Highway Traffic and Safety Administration
US Department of Transportation

Reference: Request for Comment on Automotive Electronic Control Systems Safety and Security
Docket No. NHTSA–2014–0108

Gentlemen,

In response to your request for comments on automotive electronic control systems safety and security, published in the Federal Register, Vol. 79, No. 194, on Tuesday, October 7, 2014, the enclosed comments are being provided. These comments address your request for comments made in the following sections of your request:

a. Electronics Components and the Interaction of Electronic Components

COMMENTS REQUESTED

(2) NHTSA currently has research underway that is evaluating system performance requirements for critical safety systems. We seek comment on *automotive electronic component and system performance requirements* for control systems that impact throttle, braking, steering, and motive power management:

- (a) What performance-based tests, methods, and processes are now available for safety assurance of these types of automotive electronic control systems?
- b) What series of performance-based tests should the agency consider to ensure safe functionality of these types of automotive electronic control systems under *all* real-world conditions (e.g. nominal, expected, non-nominal, and failure conditions)?

c. Effects of the Surrounding Environment on Electronic Component Performance

COMMENTS REQUESTED

(2) NHTSA has done some testing on interference issues. We seek comment in the area of *EMI/EMC*.

- (a) What could the agency do to further assess the electromagnetic interference (EMI) susceptibility impacts of growing use of electronics on automotive system safety and assess the adequacy of existing voluntary standards?

These comments have resulted from research performed by the author over a period of three years and documented in papers published at <http://www.autosafety.org/dr-ronald-belt%E2%80%99s-sudden-acceleration-papers>. The comments apply to the testing of all vehicles equipped with electronic throttles produced by all automobile, truck, and bus manufacturers. The proposed tests have not yet been verified to produce throttle openings larger than the normal responses because such testing requires vehicles and test equipment beyond the means of this author. But an accurate understanding of electronic throttle system operation shows that the tests should be effective. The comments and tests are being submitted to initiate further discussion of electronic throttle operation and how to test for failures in its operation.

Sincerely yours,

(signed)

Ronald A. Belt

REFERENCES:

- ¹ <http://www.autosafety.org/dr-ronald-belt%E2%80%99s-sudden-acceleration-papers>.
- ² R. Belt, "Comparison of Two Electronic Theories of Sudden Acceleration", <http://www.autosafety.org/dr-ronald-belt%E2%80%99s-sudden-acceleration-papers>.
- ³ "ME-Motronic Engine Management", Bosch Technical Instruction Book, September, 1999.
J. Gerhardt, H. Hönninger, and H. Bischof, "A New Approach to Functional and Software Structure for Engine Management Systems - BOSCH ME7", Electronic Engine Controls 1998: Diagnostics and Controls, <http://nyet.org/cars/info/ME7sw.pdf>
"UAES Engine Management Systems ME7 Presentation", PowerPoint presentation,
http://www.link168.com.cn/UserFiles/%E6%96%B0%E6%B7%BB%E5%8A%A0/%E5%9B%BD%E4%BA%A7/%E5%8E%9F%E5%8E%82%E5%9F%B9%E8%AE%AD/%E4%B8%80%E6%B1%BD%E5%A4%A7%E4%BC%97%E5%86%85%E9%83%A8%E5%9F%B9%E8%AE%AD%E8%B5%84%E6%96%994.42G/SSP/SSP/ME7_Presentation_English_010315.pdf
- ⁴ US patent 6,205,973 B1, "Method and arrangement for determining the torque of an internal combustion engine having direct gasoline injection", Robert Bosch GmbH, March 27, 2001.
US patent 6,512,983 B1, "Method for determining the controller output for controlling fuel injection engines", Robert Bosch GmbH, January 28, 2003.
US patent 7,051,710 B2, "Method and device for controlling an internal combustion engine", Robert Bosch GmbH, May 30 2006.
US patent 7,346,445 B2, "Method for operating an internal combustion engine having torque monitoring", Robert Bosch GmbH, March 18, 2008.
US patent 7,500,465 B2, "Method for operating an internal combustion engine", Robert Bosch GmbH, March 10, 2009.
US patent 8,000,875 B2, "Method and device as well as computer program for controlling an internal combustion engine", Robert Bosch GmbH, August 16, 2011.
- ⁵ "Understanding ECU Remapping: The Audi TT 1.8T Variants/Bosch Motronic ME7.x", <http://contiman.free.fr/reprog-/reprogrammation%20moteur%201.8t.pdf>, Robert Bosch GmbH, March 27, 2001.
- ⁶ This finding is one of the most compelling reasons why the author believes that his theory of sudden acceleration is correct.
- ⁷ Sungji Park, "Experimental Study of Reappearance for Sudden Acceleration Incidents", World Forensic Festival 2014, Seoul, Korea, October 12-18, 2014, Abstract of oral presentation, p.289.
- ⁸ Nefimoto at http://www.nefariousmotorsports.com/wiki/index.php/Main_Page
VW Vortex at <http://forums.vwvortex.com/showthread.php?5935270-UnOfficial-Eurodyne-Maestro-Tuning-Handbook>
<http://s4wiki.com/wiki/Tuning>
RX8 Club at <http://www.rx8club.com/series-i-engine-tuning-forum-63/does-cobb-access-port-%3D-throttle-controller-247184/>
CePaVW.org at <http://www.cepavw.org/phpbb3/viewtopic.php?t=22354>
- ⁹ Auto manufacturers get this load value from their air conditioner suppliers.
<http://www.shoppok.com/greenville/a.61.16146.--Lead-Engine-Control-System-Calibration-Engineer--Anderson-.htm>
- ¹⁰ F1 racers use Moog E024 subminiature servo valves for the electronic throttle and a standardized McClaren-designed F1 engine controller that uses an inverse map to control the throttle. The E024 servo valves operate in only two positions, open and closed, but can regulate the air charge to any desired amount by driving them with a pulse width modulated (PWM) waveform so that the desired air charge is proportional to the PWM duty cycle.
- ¹² For a discussion of sudden unintended acceleration in several Lotus automobiles with stick shift see: <http://www.lotustalk.com-/forums/f170/stuck-throttle-wide-open-187001/index2.html>
- ¹³ Mother Nature is another name for the renowned scientist Murphy, who stated the famous law: "If anything can go wrong, it will."
- ¹⁴ Sudden acceleration has even been observed in luxury automobiles, such as Bentleys and Jaguars. See the following references:
 - a. <http://onlineathens.com/local-news/2015-01-30/elderly-athens-woman-unhurt-bentley-drives-ledge-lands-upside-down-car>
 - b. <http://www.caranddriver.com/reviews/2002-bentley-arnage-t-road-test-review>
 - c. http://www.fixya.com/cars/t1217499-unintended_acceleration
 - d. <http://www.gossipextra.com/2012/03/15/bentley-motors-goodman-duit-1283/>
 - e. <http://www.morrisanderson.com/resource-center/entry/THE-BENTLEY-DEFENSE-HEADLINE2-Automaker-disputes-computer-malfunction-or-su/>
 - f. <http://forums.edmunds.com/discussion/16214/jaguar/xj-series/jaguar-xj-series-sudden-acceleration>