

**EXPERIMENTAL TEST OF OCCUPANT ENTRAPMENT**

**FORD TAURUS INTO REAR OF FORD EXPLORER  
30% OFFSET, 70 MPH**

**Test Date: August 3, 2010**

**Final Report Date: September 25, 2010**

## **SECTION 1**

### **PURPOSE AND SUMMARY OF TEST**

#### **PURPOSE**

The purpose of this 70 mph, 30% offset rear impact test is to examine the occurrence of occupant entrapment in high-speed offset rear impacts.

#### **SUMMARY**

A 1995 Ford Explorer was impacted in the rear by a 2003 Ford Taurus at a velocity of 70 mph. The Explorer and Taurus were set so the right vertical edge of the front of the Taurus would contact the Explorer rear 355.6 mm in right of the Explorer's longitudinal centerline. The test was performed at the Federal Outdoor Impact Laboratory on August 5, 2010.

Three real time cameras and eight high-speed cameras were used to document the rear impact event.

One 50<sup>th</sup> percentile male anthropomorphic test device (ATD) was placed in the driver seating position approximately according to dummy placement instructions specified in the FMVSS 208 Laboratory Indicant Test Procedure.

The ATD was not instrumented for this test.

The 21 channels of data were recorded with an on-board data acquisition system.

As a result of the impact, the driver's side door of the Explorer experienced crush resistance but could be opened after the test. The passenger's side door of the Explorer was fully operational after the test.

## SECTION 2

### OCCUPANT AND VEHICLE INFORMATION / DATA SHEETS

#### DATA SHEET NO. 1

##### BULLET VEHICLE CRASH TEST SUMMARY

Bullet Vehicle: 2003 Ford Taurus  
Test Program: 70 MPH 30% Offset Rear Impact Test Date: 8/5/10

##### BULLET VEHICLE PRIMARY IMPACT DATA

Measured Parameter	Units	Value
Bullet Vehicle Velocity At Impact	kph	109.4
Bullet Vehicle Test Weight	kg	1414
Bullet Vehicle Maximum Static Crush	mm	540
Impact Point	mm	NA

##### DOOR OPENING AND SEAT TRACK INFORMATION: BULLET VEHICLE

Description	Driver	Passenger
Front Door Opening	Functional	Crush Locked
Rear Door Opening	Functional	Crush Resistance
Seat Track Shift (mm)	-	-
Seat Back Failure (deg)	-	-

##### TEST DUMMY INFORMATION: BULLET VEHICLE

Description	Driver	Passenger
Dummy Type	-	-
Head Contact	-	-
Chest Contact	-	-
Abdomen Contact	-	-
Left Knee Contact	-	-
Right Knee Contact	-	-

##### VIDEO COVERAGE

High Speed	8
Real Time	3
Total	11

Driver ATD Sensors	-
Passenger ATD Sensors	-
Bullet Vehicle Structure Accelerometers	9
Target Vehicle Structure Accelerometers	12
Total	21

**DATA SHEET NO. 2**

**GENERAL TEST AND BULLET VEHICLE PARAMETER DATA**

Bullet Vehicle: 2003 Ford Taurus  
 Test Program: 70 MPH 30% Offset Rear Impact Test Date: 8/5/10

**BULLET VEHICLE INFORMATION**

Manufacturer	Ford
Model	Taurus
Body Style	4DR Sedan
Vehicle No.	1
VIN	1FAFP55263A177881
Color	Blue
Delivery Date	-
Odometer Reading	131,417
Dealer	Capital Auto Auction
Transmission	Automatic
Final Drive	FWD
Number of Cylinders	6
Engine Displacement (L)	3.0L
Engine Placement	Transverse

**TEST VEHICLE OPTIONS**

Driver Airbag	Y
Passenger Airbag	Y
Anti-theft System	Y
Cruise Control	Y
Power Windows	Y
Power Steering	Y
Power Door Locks	Y
Tilt Wheel	Y
Air Conditioning	Y
Power Brakes	Y
Disc Brakes, Front	Y
Disc Brakes, Rear	Drum
Anti-lock Brakes	Y
AM / FM / Cassette	Y

**DATA FROM CERTIFICATION LABEL**

Manufactured By	Ford Motor Company	GVWR (kg)	2124
Date of Manufacture	12/02	GAWR Front (kg)	1157
		GAWR Rear (kg)	967

**DATA FROM TIRE PLACARD**

Measured Parameter	Front	Rear
Maximum Tire Pressure (psi)	-	-
Cold Pressure (psi)	30 psi	30 psi
Recommended Tire Size	P215/60R16	P215/60R16
Tire Size On Vehicle	-	-
Tire Manufacturer	-	-

Measured Parameter	Front	Rear	Third	Total
Type of Seats	Bucket	Bench	-	-
Number of Occupants	2	3	-	5
Capacity Wt. (VCW) (kg)				
Cargo Wt. (RCLW) (kg)				

### DATA SHEET NO. 3

#### BULLET VEHICLE PARAMETER DATA

Bullet Vehicle: 2003 Ford Taurus  
Test Program: 70 MPH 30% Offset Rear Impact Test Date: 8/5/10

#### BULLET VEHICLE WEIGHTS

	Units	As Delivered (UVW) (Axle)			As Tested (ATW) (Axle)		
		Front	Rear	Total	Front	Rear	Total
Left	kg	464.0	239.5	703.5	445.0	275.5	720.5
Right	kg	464.5	217.5	682.0	438.5	255.0	693.5
Ratio	%	67%	33%	-	62%	38%	-
Totals	kg	928.5	457.0	1385.5	883.5	530.5	1414.0

#### BULLET VEHICLE TARGET TEST WEIGHT CALCULATION

Measured Parameter	Units	Value
Total Delivered Weight	kg	1385.5
Weight of 1 P572E ATD	kg	NA
Rated Cargo / Luggage Weight (RCLW)	kg	NA
Calculated Vehicle Target Weight (TVTW)	kg	1385.5

#### BULLET VEHICLE ATTITUDES

	Units	LF	RF	LR	RR
As Delivered	mm	-	-	-	-
As Tested	mm	710	711	686	696
Post Test	mm	665	NA	720	650

Weight of Ballast: \_\_\_\_\_

Vehicle Components Removed: Spare tire, trunk trim removed for  
Instrumentation

Weight Removed: 17.5kg

Added: Data Acquisition, Battery Box, Instrument  
Tray, Brake System

Weight Added: 46.0 kg

## DATA SHEET NO. 4

### BULLET VEHICLE TIRE INFORMATION

Bullet Vehicle: 2003 Ford Taurus

Test Program: 70 MPH 30% Offset Rear Impact

Test Date: 8/5/10

Vehicle Year	-	Vehicle Make	Ford
VIN	-	Vehicle Model	Taurus

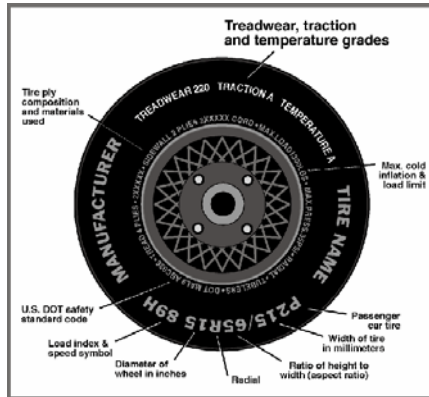

	<b>Left Front</b>	<b>Right Front</b>
Tire Manufacturer	Continental	Westlake
Tire Name	Touring Contact AS	H600
Tire Type	Radial Tubeless	Radial Tubeless
Tire Width (mm)	P215	P215
Ratio of Height to Width (aspect ratio)	60	60
Radial	R	R
Wheel Diameter	16	16
Load Index & Speed Symbol		
Treadwear	520	
Traction Grade	A	
Temperature Grade	B	
	<b>Left Rear</b>	<b>Right Rear</b>
Tire Manufacturer	Continental	Bridgestone
Tire Name	Touring Contact AS	Insignia SE 200
Tire Type	Radial Tubeless	Radial Tubeless
Tire Width (mm)	P215	P250
Ratio of Height to Width (aspect ratio)	60	60
Radial	R	R
Wheel Diameter	16	16
Load Index & Speed Symbol		
Treadwear	520	380
Traction Grade	A	B
Temperature Grade	B	B

## DATA SHEET NO. 5

### BULLET VEHICLE MEASUREMENTS

Bullet Vehicle: 2003 Ford Taurus

Test Program: 70 MPH 30% Offset Rear Impact

Test Date: 8/5/10

No.	Measurement	Units	Pre-Test	Post-Test	Diff
1	Total length of vehicle at centerline	mm	5029	4547	483
2	RSOV to front of engine	mm	4420	4191	229
3	RSOV to firewall centerline	mm	3810	3835	-25
4	RSOV to leading edge of right door	mm	3512	3512	0
5	RSOV to leading edge of left door	mm	3531	3531	0
6	RSOV to lower leading edge of right door	mm	3442	3429	13
7	RSOV to lower leading edge of left door	mm	3429	3429	0
8	RSOV to upper leading edge of right door	mm	3473	3480	-6
9	RSOV to upper leading edge of left door	mm	3467	3467	0
	RSOV to trailing edge of right door	mm	2400	2413	-13
	RSOV to trailing edge of left door	mm	2413	2413	0
10	RSOV to lower trailing edge of right door	mm	2343	2350	-6
11	RSOV to lower trailing edge of left door	mm	2343	2362	-19
	RSOV to upper trailing edge of right door	mm	2375	2394	-19
	RSOV to upper trailing edge of left door	mm	2381	2356	25
	RSOV to trailing edge of rear right door	mm	1422	1422	0
	RSOV to trailing edge of rear left door	mm	1397	1397	0
	RSOV to lower trailing edge of rear right door	mm	1689	1664	25
	RSOV to lower trailing edge of rear left door	mm	1626	1670	-44
	RSOV to upper trailing edge of rear right door	mm	1410	1448	-38
	RSOV to upper trailing edge of rear left door	mm	1397	1397	0
12	RSOV to bottom of right 'A' pillar	mm	3378		
13	RSOV to bottom of left 'A' pillar	mm	3404	3391	13
	RSOV to bottom of right 'B' pillar	mm	3426		
	RSOV to bottom of left 'B' pillar	mm	2413	2413	0
	RSOV to bottom of right 'C' pillar	mm	1651		
	RSOV to bottom of left 'C' pillar	mm	1676	1676	0
14	RSOV to firewall on right side	mm	3620		
15	RSOV to firewall on left side	mm	3658	3632	25
16	RSOV to steering column	mm	3010	3023	-13
17	Center of steering column to left 'A' pillar	mm	445	419	25
18	Center of steering column to headlining	mm	394	394	0
19	RSOV to right side of front bumper	mm	4648		
20	RSOV to left side of front bumper	mm	4648	4648	0
21	Length of Engine Block	mm			
RD	RSOV to right side of dash panel	mm	3124	3099	25
CD	RSOV to center of dash panel	mm			
LD	RSOV to left side of dash panel	mm	3150	3150	0

DATA SHEET NO. 5... (continued)

**BULLET VEHICLE MEASUREMENTS**

Bullet Vehicle:

2003 Ford Taurus

Test Program:

70 MPH 30% Offset Rear Impact

Test Date:

8/5/10

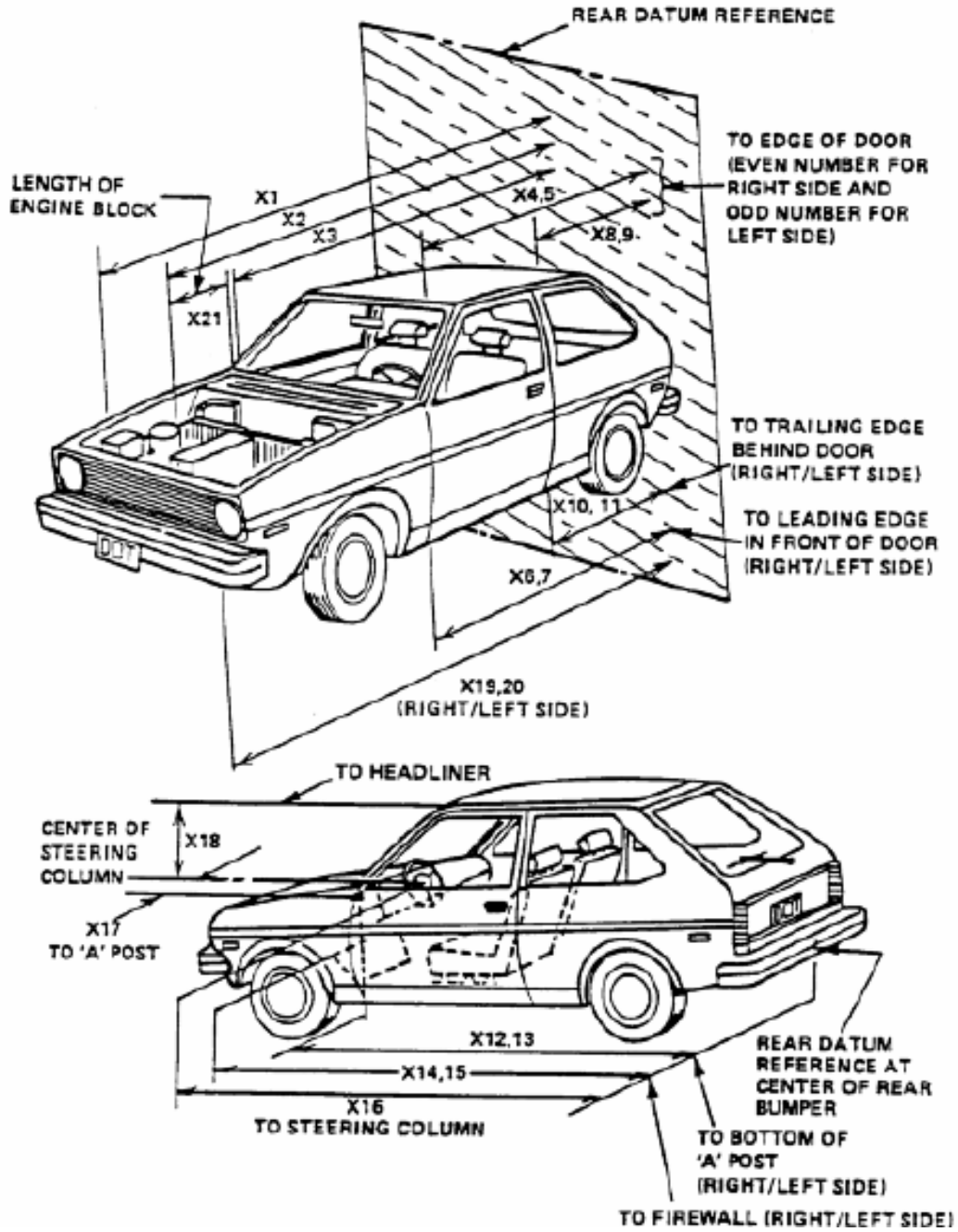



**DATA SHEET NO. 5... (Continued)**

**BULLET VEHICLE MEASUREMENTS**

Bullet Vehicle: 2003 Ford Taurus

Test Program: 70 MPH 30% Offset Rear Impact

Test Date: 8/5/10

	Elements	Measurement (mm)
1	Total Length	5029
2	Total Width	1829
3	Front Bumper Top Height	533
4	Front Bumper Bottom Height	381
5	Longitudinal Member Top Height	737
6	Distance Between Longitudinal Members	1422
7	Longitudinal Member Width	127
8	Engine Top Height	
9	Engine Bottom Height	
10	Engine and Gearbox Width	
11	Front Bumper – Engine Distance	584
12	Front Shock Absorber Fixing Height	889
13	Bonnet Leading Edge Height	711
14	Front Shock Absorber Fixing Width	118
15	Front Axle – Distance from RSOV	4001
16	Rear Axle – Distance from RSOV	1219
17	A-Pillar – B-Pillar Distance	
18	C-Pillar – Rear Axle Distance	
19	B-Pillar – C-Pillar Distance	
20	Roof Sill Bottom Height	1270
21	Roof Sill Top Height	1359
22	Floor Sill Bottom Height	279
23	Floor Sill Top Height	368

**DATA SHEET NO. 6**

**BULLET VEHICLE ACCELEROMETER LOCATIONS & MEASUREMENTS**

Bullet Vehicle: 2003 Ford Taurus

Test Program: 70 MPH 30% Offset Rear Impact

Test Date: 8/5/10

Location	X (mm)	Y (mm)	Z (mm)
CG	3010	864	368

X Reference from the rear bumper – positive towards the front of the vehicle

Y Reference from the passenger’s side – positive towards the driver’s side of the vehicle

Z Reference from the ground – positive up

Description of Instrumentation Included:

One triaxial accelerometer with a redundant, one triaxial roll rate

---

---

---

---

---

---

**DATA SHEET NO. 7**

**BULLET VEHICLE PHOTOGRAPHIC REFERENCE TARGET LOCATIONS**

Bullet Vehicle: 2003 Ford Taurus

Test Program: 70 MPH 30% Offset Rear Impact

Test Date: 8/5/10

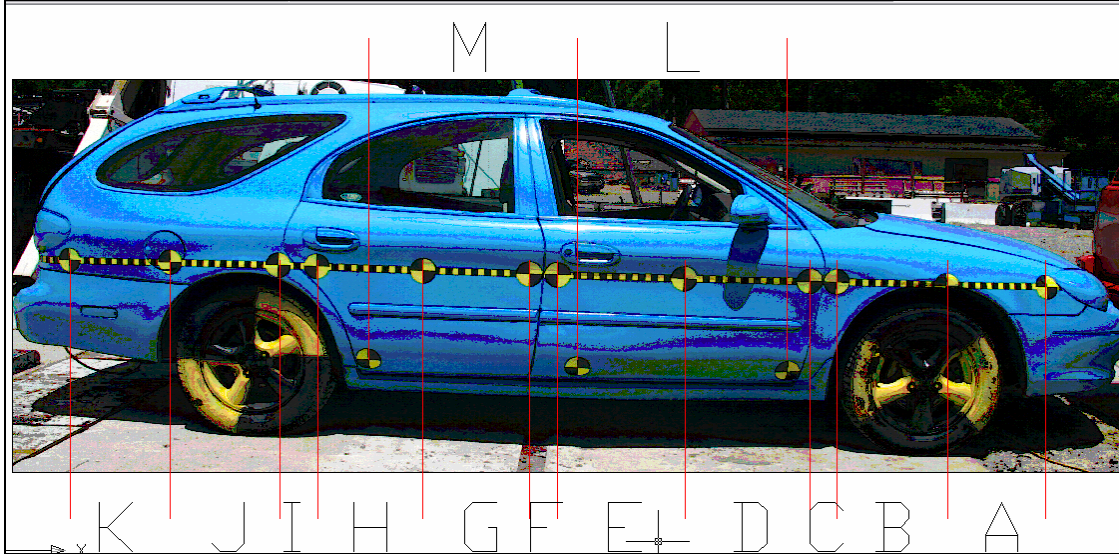

**Side Marker Measurements**

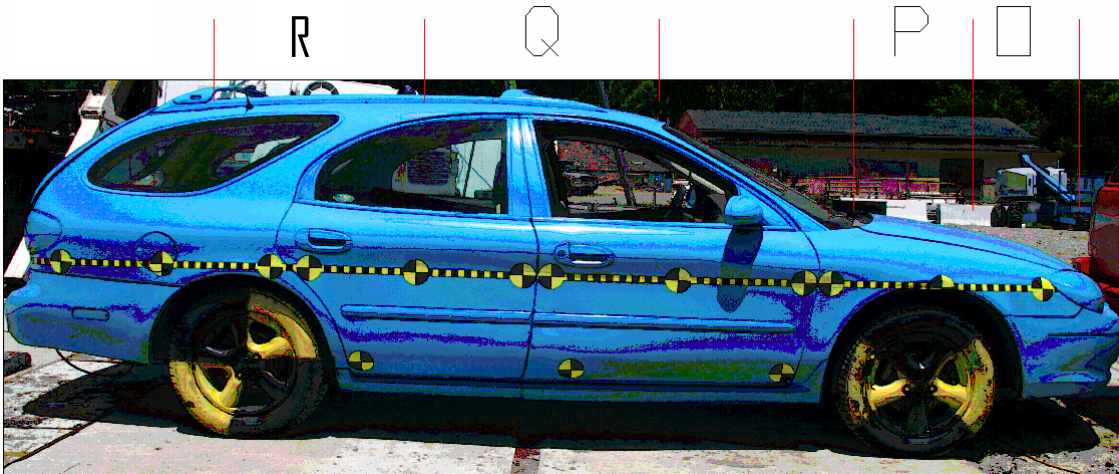

**Top Marker Measurements**

**DATA SHEET NO. 7**

**BULLET VEHICLE PHOTOGRAPHIC REFERENCE TARGET LOCATIONS**

Bullet Vehicle: 2003 Ford Taurus

Test Program: 70 MPH 30% Offset Rear Impact

Test Date: 8/5/10

	Driver's Side Middle		Passenger's Side Middle	
	Pre	Post	Pre	Post
A	438 mm	435	436	NA
B	438	435	440	NA
C	111	100	109	NA
D	497	497	501	497
E	497	497	501	500
F	109	105	110	102
G	440	440	434	434
H	436	436	437	437
I	149	149	150	145
J	460	460	455	455
K	445	446	460	460
	Driver's Side Low		Passenger's Side Low	
L	850	850	828	828
M	830	833	828	828
	Top			
	Pre		Post	
O	473		330	
P	464		330	
Q	750		750	
R	750		750	

## DATA SHEET NO. 8

### BULLET VEHICLE INTRUSION MEASUREMENTS

Bullet Vehicle: 2003 Ford Taurus

Test Program: 70 MPH 30% Offset Rear Impact

Test Date: 8/5/10

#### DOOR OPENING WIDTH

Item	Description	Units	Pre-Test	Post-Test	Difference
A	Left Side Upper	mm	960	955	5
B	Left Side Lower	mm	920	920	0
D	Right Side Upper	mm	980	NA	
E	Right Side Lower	mm	920	NA	
	Rear Left Side Upper	mm	920	910	10
	Rear Left Side Lower	mm	670	670	0
	Rear Right Side Upper	mm	920	NA	
	Rear Right Side Lower	mm	670	NA	

#### WHEELBASE MEASUREMENTS

Item	Description	Units	Pre-Test	Post-Test	Difference
C	Left Side Wheelbase	mm	2756	2769	-13
F	Right Side Wheelbase	mm	2756	2654	102

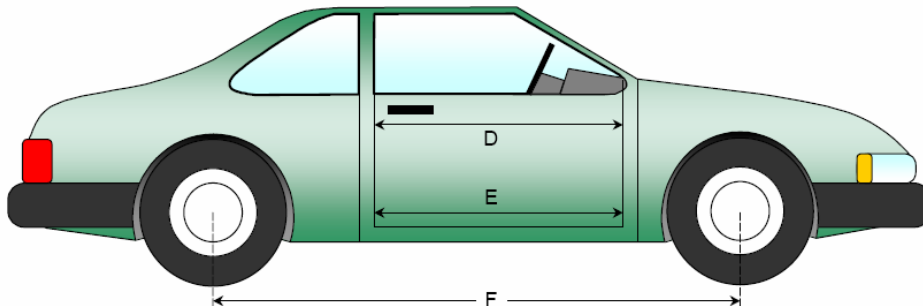
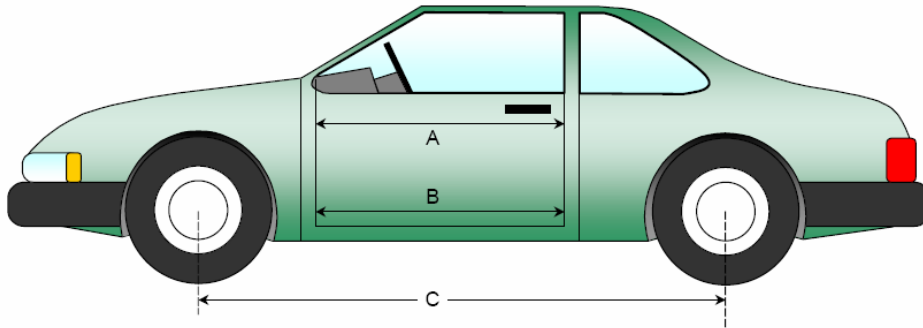

## DATA SHEET NO. 9

### BULLET VEHICLE INTRUSION MEASUREMENTS

Bullet Vehicle: 2003 Ford Taurus

Test Program: 70 MPH 30% Offset Rear Impact

Test Date: 8/5/10

#### DRIVER COMPARTMENT INTRUSION

Item	Description	Units	Pre-Test	Post-Test	Difference
AB	Door Opening (inside window jam)	mm	-	-	-
CX	Left Knee Bolster to X	mm	-	-	-
DX	Right Knee Bolster to X	mm	-	-	-
EX	Brake Pedal to X	mm	-	-	-
FX	Foot Rest to X	mm	-	-	-
GX	Center of Steering Column Wheel Hub to X	mm	-	-	-

X = Front of Seat Track (stationary)

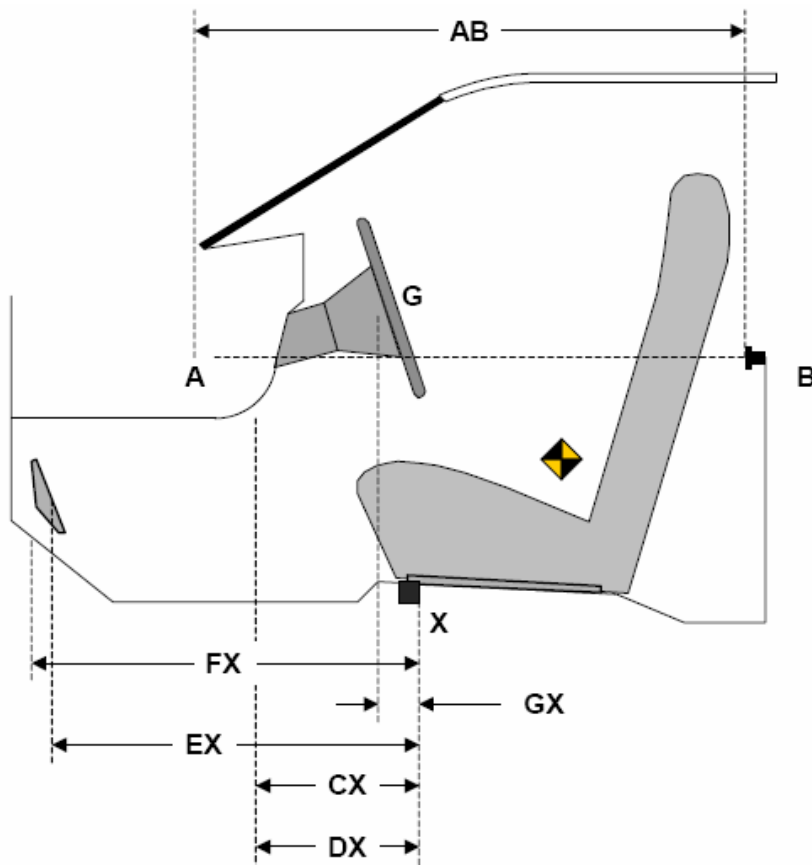

**DRIVER COMPARTMENT**

## DATA SHEET NO. 9

### BULLET VEHICLE ACCIDENT INVESTIGATION DIVISION DATA

Bullet Vehicle: 2003 Ford Taurus  
 Test Program: 70 MPH 30% Offset Rear Impact Test Date: 8/5/10

#### VEHICLE INFORMATION

VIN: 1FAFP55263A177881 Wheelbase (mm): 275.6  
 Vehicle Size Category: 3 Test Weight (kg): 1414.0

#### ACCELEROMETER DATA

Accelerometer Locations: approx. at c.g., see accel. data sheet  
 Cal. Procedure / Interval: -  
 Integration Algorithm: - Linearity: -  
 Impact Velocity (kph): 110 kph  
 Velocity Change (kph): 73.4 kph Time of Separation (ms): 150

#### CRUSH PROFILE

Collision Deformation Classification: 12FWZE4 Midpoint of damage -279 mm  
 Damage Region Length (mm): 1270 mm Impact Mode: Frontal Offset

mm			Passenger' Side							CL	Driver's Side						
Desc.	Height		203	305	406	508	610	711	813	914	1016	1118	1219	1321	1422	1524	1626
		Pre	190	122	75	46	22	0	0	0	0	0	15	35	68	110	170
		Post		500	460	460	480	540	528	510	470	455	445	185	250	350	350
Mid-Bumper	482.6	Crush		-378	-385	-414	-458	-540	-528	-510	-470	-455	-430	-150	-182	-240	-180
		Pre	300	250	205	167	163	160	150	148	150	155	160	160	172	222	290
		Post	1300	810	930	655	675	700	710	710	675	660	535	545	465	460	470
Hood Edge	698.5	Crush	-1000	-560	-725	-488	-512	-540	-560	-562	-525	-505	-375	-385	-293	-238	-180

## DATA SHEET NO. 10

### TARGET VEHICLE CRASH TEST SUMMARY

Target Vehicle: 1995 Ford Explorer  
Test Program: 70 MPH 30% Offset Rear Impact Test Date: 8/5/10

### TARGET VEHICLE PRIMARY IMPACT DATA

Measured Parameter	Units	Value
Target Vehicle Velocity At Impact	kph	0.0
Target Vehicle Test Weight	kg	1812.0
Target Vehicle Maximum Static Crush	mm	705
Impact Point	mm	-

### DOOR OPENING AND SEAT TRACK INFORMATION: TARGET VEHICLE

Description	Driver	Passenger
Front Door Opening	Crush Resistance	Fully functional
Rear Door Opening	-	-
Seat Track Shift (mm)	130 mm rearward to full rear	-
Seat Back Failure (deg)	To 44 deg rearward from 18 deg	-

### TEST DUMMY INFORMATION: TARGET VEHICLE

Description	Driver	Passenger
Dummy Type	HII 50 <sup>th</sup>	-
Head Contact	Seat back, rear seat, d-ring	-
Chest Contact	-	-
Abdomen Contact	-	-
Left Knee Contact	-	-
Right Knee Contact	-	-

### VIDEO COVERAGE

High Speed	8
Real Time	3
Total	11

Driver ATD Sensors	-
Passenger ATD Sensors	-
Bullet Vehicle Structure Accelerometers	9
Target Vehicle Structure Accelerometers	12
Total	21



**DATA SHEET NO. 11**

**GENERAL TEST AND TARGET VEHICLE PARAMETER DATA**

Target Vehicle: 1995 Ford Explorer

Test Program: 70 MPH 30% Offset Rear Impact

Test Date: 8/5/10

**TARGET VEHICLE INFORMATION**

Manufacturer	Ford
Model	Explorer Sport
Body Style	2DR SUV
Vehicle No.	2
VIN	1FMCU24X6SUB74635
Color	Red
Delivery Date	
Odometer Reading	203,660
Dealer	Capital Auto Auction
Transmission	Automatic
Final Drive	4WD
Number of Cylinders	6
Engine Displacement (L)	4.0 L
Engine Placement	Longitudinal

**TEST VEHICLE OPTIONS**

Driver Airbag	Y
Passenger Airbag	Y
Anti-theft System	
Cruise Control	Y
Power Windows	Y
Power Steering	Y
Power Door Locks	Y
Tilt Wheel	Y
Air Conditioning	Y
Power Brakes	Y
Disc Brakes, Front	Y
Disc Brakes, Rear	Y
Anti-lock Brakes	
AM / FM / Cassette	Y

**DATA FROM CERTIFICATION LABEL**

Manufactured By	Ford Motor Company
Date of Manufacture	5/95

GVWR (kg)	2222 kg
GAWR Front (kg)	1138 kg
GAWR Rear (lkg)	1202 kg

**DATA FROM TIRE PLACARD**

Measured Parameter		
Maximum Tire Pressure (psi)	-	-
Cold Pressure (psi)	26 psi	26 psi
Recommended Tire Size	P235/75R15	P235/75R15
Tire Size On Vehicle	-	-
Tire Manufacturer	-	-

Measured Parameter	Front	Rear	Third	Total
Type of Seats	Bucket	Bench	-	
Number of Occupants	2	3	-	5
Capacity Wt. (VCW) (kg)				
Cargo Wt. (RCLW) (kg)				

**DATA SHEET NO. 12**

**GENERAL TEST AND TARGET VEHICLE PARAMETER DATA**

Target Vehicle: 1995 Ford Explorer  
Test Program: 70 MPH 30% Offset Rear Impact Test Date: 8/5/10

**TARGET VEHICLE WEIGHTS**

	Units	As Delivered (UVW) (Axle)			As Tested (ATW) (Axle)		
		Front	Rear	Total	Front	Rear	Total
Left	kg	488.5	408.5	897.0	515.0	439.5	954.5
Right	kg	453.5	371.5	825.0	466.5	391.0	857.5
Ratio	%	56%	44%	-	54%	46%	-
Totals	kg	942.0	726.0	1668.0	981.5	830.5	1812.0

**TARGET VEHICLE TARGET TEST WEIGHT CALCULATION**

Measured Parameter	Units	Value
Total Delivered Weight	kg	1668.0
Weight of 1 P572E ATD	kg	78.0
Rated Cargo / Luggage Weight (RCLW)	kg	-
Calculated Vehicle Target Weight (TVTW)	kg	1744.0

**TARGET VEHICLE ATTITUDES**

	Units	LF	RF	LR	RR
As Delivered	mm	-	-	-	-
As Tested	mm	893	900	897	900
Post Test	mm	870	935	960	845

Weight of Ballast: \_\_\_\_\_

Vehicle Components Removed: oil, transmission fluid, antifreeze

Weight Removed: 18 kg

Added: battery box, data acquisition, brake system, atd

Weight Added: 108.0 kg

## DATA SHEET NO. 13

### TARGET VEHICLE TIRE INFORMATION

Target Vehicle: 1995 Ford Explorer

Test Program: 70 MPH 30% Offset Rear Impact

Test Date: 8/5/10

Vehicle Year	-	Vehicle Make	-
VIN	-	Vehicle Model	-

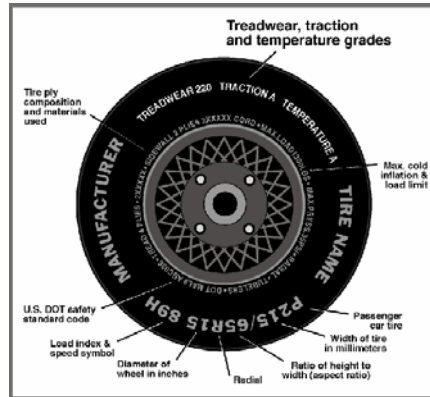

	<b>Left Front</b>	<b>Right Front</b>
Tire Manufacturer	Goodyear	Goodyear
Tire Name	Wrangler RTS	Wrangler RTS
Tire Type	Tubeless Radial	Tubeless Radial
Tire Width (mm)	P235	P235
Ratio of Height to Width (aspect ratio)	75	75
Radial	R	R
Wheel Diameter	15	15
Load Index & Speed Symbol		
Treadwear	340	340
Traction Grade	A	A
Temperature Grade	B	B
	<b>Left Rear</b>	<b>Right Rear</b>
Tire Manufacturer	Goodyear	Michelin
Tire Name	Wrangler RTS	X Radial LT
Tire Type	Tubeless Radial	Tubeless Radial
Tire Width (mm)	P235	235
Ratio of Height to Width (aspect ratio)	75	75
Radial	R	R
Wheel Diameter	15	15
Load Index & Speed Symbol		Load Range C
Treadwear	340	
Traction Grade	A	
Temperature Grade	B	

**DATA SHEET NO. 14**

**TARGET VEHICLE SEAT INFORMATION**

Target Vehicle: 1995 Ford Explorer

Test Program: 70 MPH 30% Offset Rear Impact

Test Date: 8/5/10

**NORMAL DESIGN RIDING POSITION**

Driver Seat Back Angle: 18 deg

Passenger Seat Back Angle: -- deg

(20° rearward of most forward locked position.)

**SEAT FORE / AFT POSITION**

The driver and passenger seats are operated:  
(**manually** / electrically)

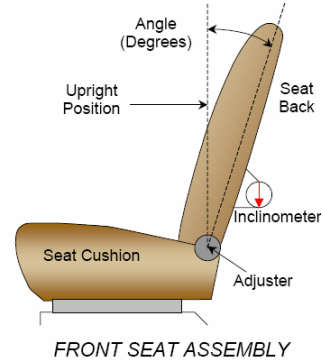

Driver Seat Fore / Aft Total Travel: 250 positions / **mm**

Passenger Seat Fore / Aft Total Travel: - positions / **mm**

As Tested:

Driver Seat Fore / Aft Position: center of track, 125 mm from front position

Passenger Seat Fore / Aft Position: -

**SEAT BELT UPPER ANCHORAGE**

The seat belt anchorages were placed in \_\_\_\_\_ position of \_\_\_\_\_ with the top position as one.

or No Adjustment Available

**SEAT HEIGHT ADJUSTMENT**

Seat is positioned at its lowest setting

**NOTES:** \_\_\_\_\_  
\_\_\_\_\_

**DATA SHEET NO. 14... (continued)**

**TARGET VEHICLE INFORMATION**

Target Vehicle: 1995 Ford Explorer

Test Program: 70 MPH 30% Offset Rear Impact

Test Date: 8/5/10

**STEERING COLUMN ADJUSTMENT**

The steering column was placed in the mid position of travel.

Pos.	Desc	Angle
3	Full Up	<u>65.0 deg</u>
2	Center	<u>72.5 deg</u>
1	Full Down	<u>80.0 deg</u>

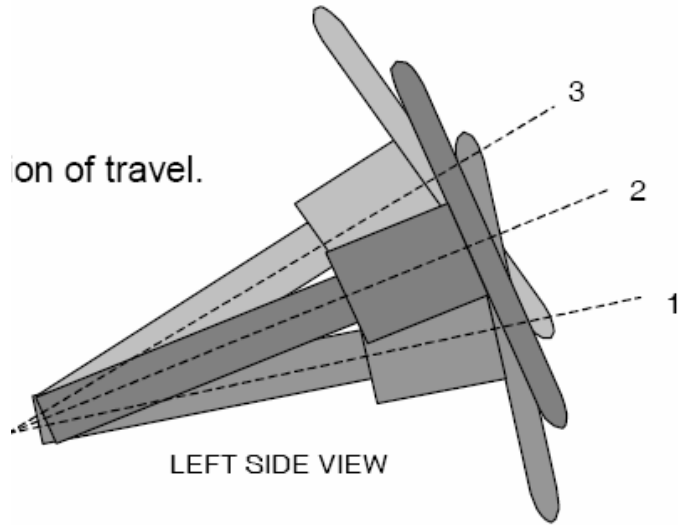

**STEERING COLUMN ASSEMBLY**

## DATA SHEET NO. 15

### TARGET VEHICLE DUMMY POSITIONING IN VEHICLE

Target Vehicle: 1995 Ford Explorer

Test Program: 70 MPH 30% Offset Rear Impact

Test Date: 8/5/10

#### DUMMY MEASUREMENTS FOR FRONT SEAT OCCUPANTS

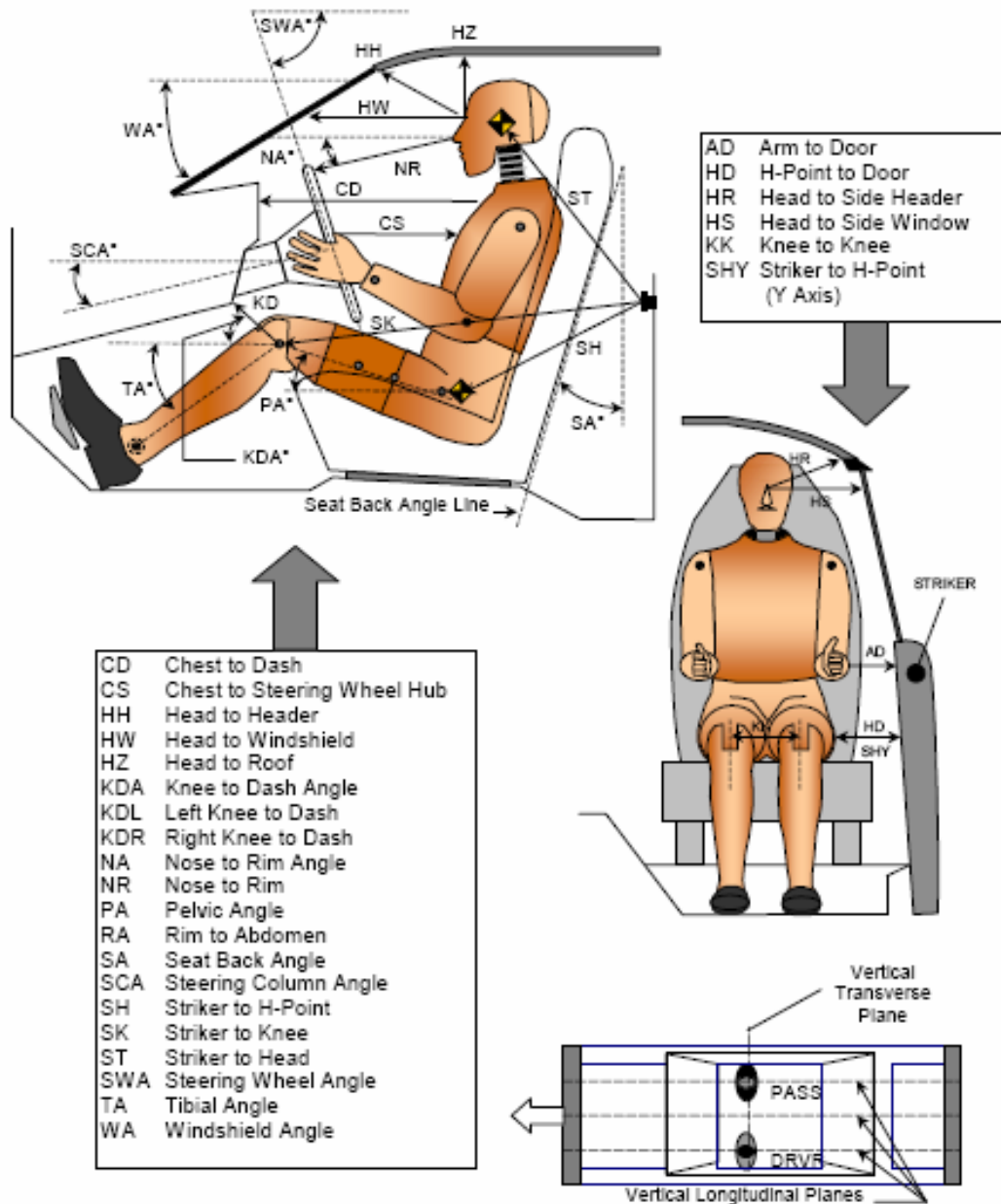

**DATA SHEET NO. 15...(continued)**

**TARGET VEHICLE DUMMY POSITIONING IN VEHICLE**

Target Vehicle: 1995 Ford Explorer

Test Program: 70 MPH 30% Offset Rear Impact

Test Date: 8/5/10

Code	Measurement Description	Driver		Passenger	
		Length (mm)	Angle (°)	Length (mm)	Angle (°)
WA	Windshield Angle		42 deg		-
SWA	Steering Wheel Angle		72.5 deg		-
SCA	Steering Column Angle		20 deg		-
SA	Seat Back Angle (head rest post)		18 deg		-
HZ	Head to Roof (Z)	240		-	
HH	Head to Header	320		-	
HW	Head to Windshield	590		-	
HR	Head to Side Header (Y)	275		-	
NR	Nose to Rim	440		-	
CD	Chest to Dash	590		-	
CS	Chest to Steering Hub	300		-	
RA	Rim to Abdomen			-	
KDL	Left Knee to Dash	50		-	
KDR	Right Knee to Dash	80		-	
PA	Pelvic Angle				-
TA	Tibia Angle				-
KK	Knee to Knee (Y)	200		-	
SK	Striker to Knee	830		-	
ST	Striker to Head	650		-	
SH	Striker to H-Point			-	
SHY	Striker to H-Point (Y)			-	
HS	Head to Side Window	358		-	
HD	H-Point to Door			-	
AD	Arm to Door (Y)	0		-	
AA	Ankle to Ankle			-	

## DATA SHEET NO. 16

### TARGET VEHICLE SEAT BELT POSITIONING DATA

Target Vehicle: 1995 Ford Explorer

Test Program: 70 MPH 30% Offset Rear Impact

Test Date: 8/5/10

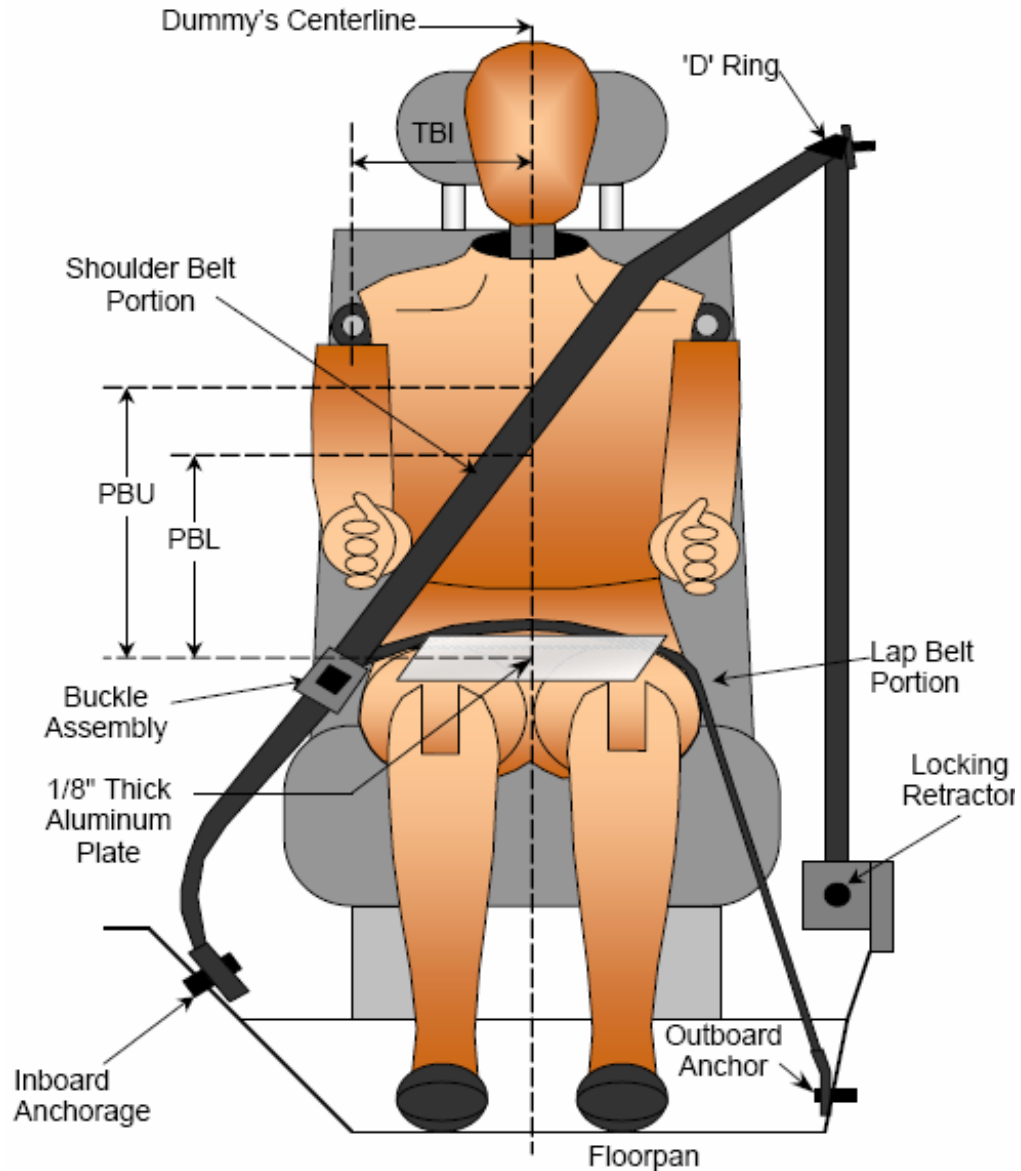

### SEAT BELT POSITIONING MEASUREMENTS

Measurement Description	Units	Driver	Passenger
PBU – Top surface of reference to belt upper edge	mm	262	-
PBL – Top surface of reference to belt lower edge	mm	182	-



## DATA SHEET NO. 17

### TARGET VEHICLE MEASUREMENTS

Target Vehicle: 1995 Ford Explorer

Test Program: 70 MPH 30% Offset Rear Impact

Test Date: 8/5/10

No.	Measurement	Units	Pre-Test	Post-Test	Difference
1	Total length of vehicle at centerline	Mm	4470	3730	740
4	FSOV to leading edge of right door	Mm	1435	1461	-25
5	FSOV to leading edge of left door	Mm	1435	1448	-13
6	FSOV to lower leading edge of right door	Mm	1486	1473	13
7	FSOV to lower leading edge of left door	Mm	1499	1511	-13
8	FSOV to upper leading edge of right door	Mm	1435	1448	-13
9	FSOV to upper leading edge of left door	Mm	1435	1473	-38
	FSOV to trailing edge of right door	Mm	2667	2667	0
	FSOV to trailing edge of left door	Mm	2667	2680	-13
10	FSOV to lower trailing edge of right door	Mm	2667	2667	0
11	FSOV to lower trailing edge of left door	Mm	2667	2680	-13
	FSOV to upper trailing edge of right door	Mm	2667	2667	0
	FSOV to upper trailing edge of left door	Mm	2667	2680	-13
	FSOV to trailing edge of rr door	Mm	-	-	-
	FSOV to trailing edge of lr door	Mm	-	-	-
	FSOV to lower edge of rr door	Mm	-	-	-
	FSOV to lower edge of lr door	Mm	-	-	-
	FSOV to upper trailing edge of rr door	Mm	-	-	-
	FSOV to upper trailing edge of lr door	Mm	-	-	-
12	FSOV to bottom of right 'A' pillar	Mm	1499	1549	-51
13	FSOV to bottom of left 'A' pillar	Mm	1524	1549	-25
	FSOV to bottom of right 'B' pillar	Mm	2616	2654	-38
	FSOV to bottom of left 'B' pillar	Mm	2629	2680	-51
	FSOV to bottom of right 'C' pillar	Mm	3334	3340	-6
	FSOV to bottom of left 'C' pillar	Mm	3340	3327	13
16	FSOV to steering column	Mm	-	-	-
17	Center of steering column to left 'A' pillar	Mm	420	-	-
18	Center of steering column to headlining	Mm	410	410	0
19	FSOV to right side of rear bumper	Mm	4429	4216	13
20	FSOV to left side of rear bumper	Mm	4235	3658	578
C1	Crush Zone 1 at right side	Mm	-	-	-
C2	Crush Zone 2 at right side	Mm	-	-	-
C3	Crush Zone 3 at right side	Mm	-	-	-
C4	Crush Zone 4 at left side	Mm	-	-	-
C5	Crush Zone 5 at left side	Mm	-	-	-
C6	Crush Zone 6 at left side	Mm	-	-	-

DATA SHEET NO. 17... (continued)

TARGET VEHICLE MEASUREMENTS

Target Vehicle: 1995 Ford Explorer

Test Program: 70 MPH 30% Offset Rear Impact

Test Date: 8/5/10

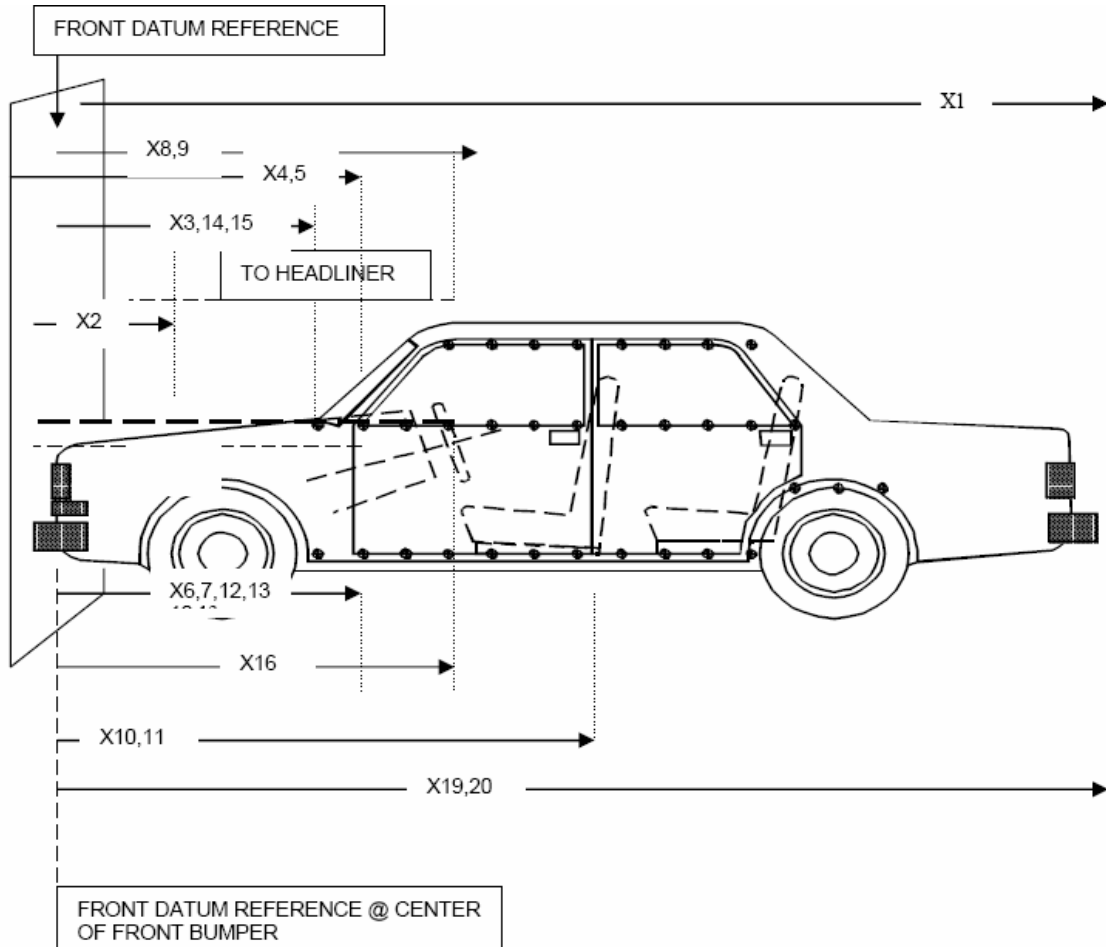

**DATA SHEET NO. 17... (Continued)**

**TARGET VEHICLE MEASUREMENTS**

Target Vehicle: 1995 Ford Explorer

Test Program: 70 MPH 30% Offset Rear Impact

Test Date: 8/5/10

	Elements	Pre-Test (mm)
1	Total Length	4470
2	Total Width	1778
3	Rear Bumper Top Height	600
4	Rear Bumper Bottom Height	400
5	Longitudinal Member Top Height	
6	Distance Between Longitudinal Members	
7	Longitudinal Member Width	
8	Front Bumper distance from FSOV	0
9	Front Axle distance from FSOV	838
10	A Pillar distance from FSOV	1486
11	B Pillar distance from FSOV	2667
12	C Pillar distance from FSOV	3353
13	Rear Bumper from FSOV	4470
14	Front Shock Absorber Fixing Width	
15	Rear Bumper – Rear Axle distance	
16	Front Axle – A Pillar Distance	
17	A-Pillar – B-Pillar Distance	
	C-Pillar – Rear Axle Distance	
	B-Pillar – C-Pillar Distance	
20	Roof Sill Bottom Height	1580
21	Roof Sill Top Height	1660
22	Floor Sill Bottom Height	320
23	Floor Sill Top Height	480

**DATA SHEET NO. 18**

**TARGET VEHICLE ACCELEROMETER LOCATIONS & MEASUREMENTS**

Target Vehicle: 1995 Ford Explorer

Test Program: 70 MPH 30% Offset Rear Impact

Test Date: 8/5/10

Location	X (mm)	Y (mm)	Z (mm)
CG	1803	902	610

X Reference from the front bumper – positive towards the rear of the vehicle

Y Reference from the driver’s side – positive towards the passenger’s side of the vehicle

Z Reference from the ground – positive up

Description of Instrumentation Included:

One triaxial accelerometer with redundant and one triaxial roll rate with redundant

---

---

---

---

---

---

**DATA SHEET NO. 19**

**TARGET VEHICLE TARGET MEASUREMENTS**

Target Vehicle: 1995 Ford Explorer

Test Program: 70 MPH 30% Offset Rear Impact

Test Date: 8/5/10

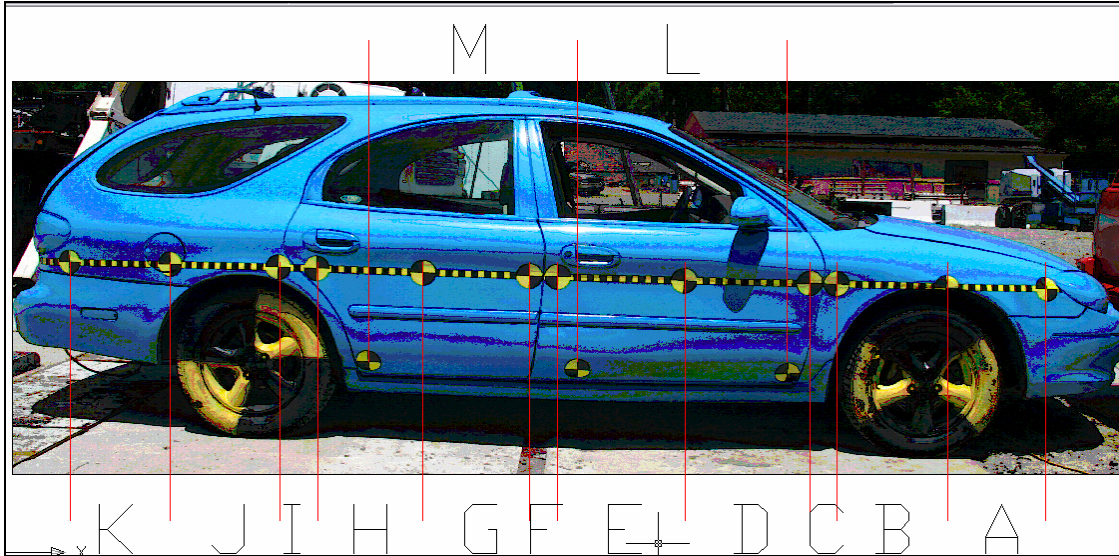

**Side Marker Measurements**

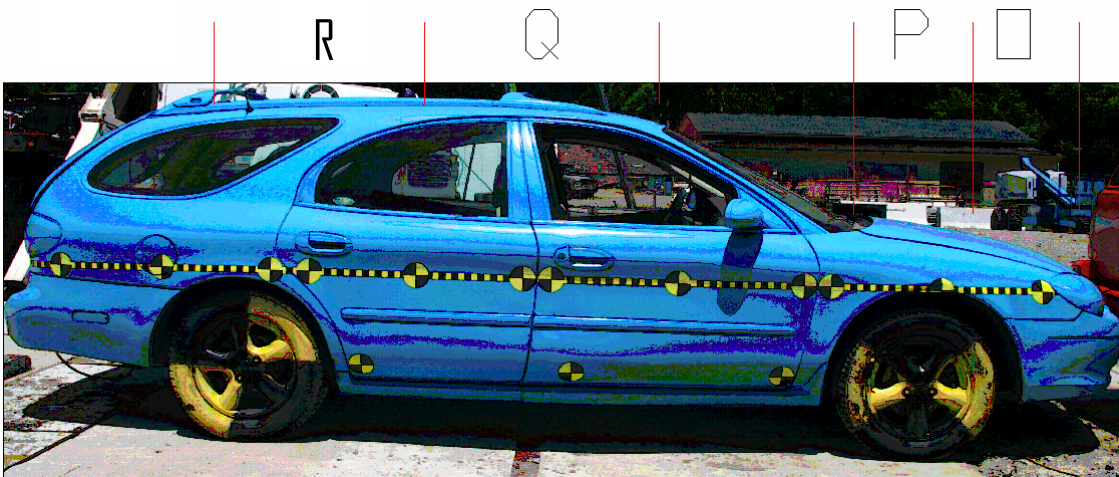

**Top Marker Measurements**

**DATA SHEET NO. 19...Continued**

**TARGET VEHICLE PHOTOGRAPHIC REFERENCE TARGET LOCATIONS**

Target Vehicle: 1995 Ford Explorer

Test Program: 70 MPH 30% Offset Rear Impact

Test Date: 8/5/10

	Driver's Side Middle		Passenger's Side Middle	
	Pre	Post	Pre	Post
A	490	490	489	489
B	495	495	488	488
C	109	102	106	106
D	562	562	558	558
E	562	562	561	561
F	110	94	110	110
G	714	678	710	710
H	720	480	718	721
I				
J				
K				
	Driver's Side Low		Passenger's Side Low	
	L	M	L	M
L	733	741	736	741
M	735	655	732	732
Top				
	Pre		Post	
	O	P	Q	R
O	480		480	
P	470		470	
Q	1015		1015	
R	1015		1015	

**DATA SHEET NO. 20**

**TARGET VEHICLE INTRUSION MEASUREMENTS**

Target Vehicle: 1995 Ford Explorer

Test Program: 70 MPH 30% Offset Rear Impact

Test Date: 8/5/10

**DOOR OPENING WIDTH**

Item	Description	Units	Pre-Test	Post-Test	Difference
A	Left Side Upper	mm	1090	1075	15
B	Left Side Lower	mm	1065	1050	15
D	Right Side Upper	mm	1090	1090	0
E	Right Side Lower	mm	1065	1060	5
	Rear Left Side Upper	mm	-	-	-
	Rear Left Side Lower	mm	-	-	-
	Rear Right Side Upper	mm	-	-	-
	Rear Right Side Lower	mm	-	-	-

**WHEELBASE MEASUREMENTS**

Item	Description	Units	Pre-Test	Post-Test	Difference
C	Left Side Wheelbase	mm	2591	2310	281
F	Right Side Wheelbase	mm	2591	2605	-14

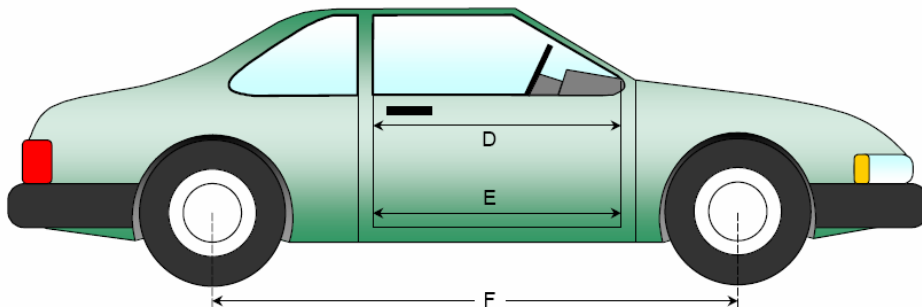
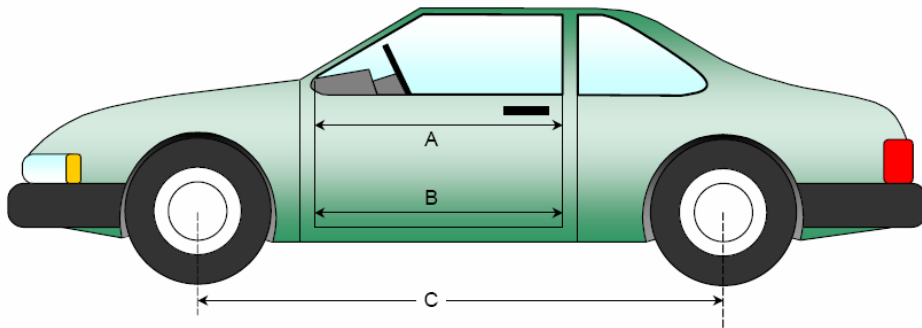

## DATA SHEET NO. 21

### TARGET VEHICLE ACCIDENT INVESTIGATION DIVISION DATA

Target Vehicle: 1995 Ford Explorer  
 Test Program: 70 MPH 30% Offset Rear Impact Test Date: 8/5/10

#### VEHICLE INFORMATION

VIN: 1FMCU24X6SUB74635 Wheelbase (mm): 2591  
 Vehicle Size Category: 3 Test Weight (kg): 1812

#### ACCELEROMETER DATA

Accelerometer Locations: approx. at c.g., see accel. data sheet  
 Cal. Procedure / Interval: -  
 Integration Algorithm: - Linearity: -  
 Impact Velocity (kph): 0 kph  
 Velocity Change (kph): 51.6 kph Time of Separation (ms): 150

#### CRUSH PROFILE

Collision Deformation Classification: 06BWYA6 Midpoint of damage: -203 mm  
 Damage Region Length (mm): 1423 mm Impact Mode: Rear Offset

mm		Driver's Side										CL	Passenger's Side							
Description	Height	76	178	279	381	483	584	686	787	889	991	1092	1194	1295	1397	1499	1600	1702		
Bumper	520	Pre		51	42	36	28	27	27	92	92	92	55	22	26	28	39	48		
		Post	NA	NA	NA	NA	NA	NA	NA	<b>797</b>	<b>730</b>	<b>400</b>	<b>315</b>	<b>305</b>	290	200	275	NA	NA	
		Crush									-705	-638	-308	-260	-283	-264	-172	-236		
<b><i>Bold Italicized = Measured on Bumper</i></b>																				
Bottom Body	660	Pre		147	122	122	118	109	105	102	102	102	105	109	113	116	125	130		
		Post	<b>785</b>	<b>730</b>	<b>708</b>	<b>705</b>	<b>690</b>	<b>675</b>	<b>805</b>	<b>770</b>	<b>490</b>	<b>440</b>	335	260	215	180	255	NA	NA	
		Crush		-583	-586	-583	-572	-566	-700	-668	-388	-338	-230	-151	-102	-64	-130			
Mid Body	1100	Pre			105		95		87		84		86		92		98			
		Post	310	300	310	297	288	275	250	218	210	218	165	150	130	111	130	255	-	
		Crush			-205		-193		-163		-126		-79		-38		-32			
Upper Body	1610	Pre			345		330		325		320		320		325		340			
		Post	NA	350	350	330	325	320	320	315	305	305	300	300	300	300	300	NA	NA	NA
		Crush			-5		5		5		15		20		25					